

The T71 programmable temperature transmitter is a 2-wire transmitter with an analog output. It has measurement input for resistance thermometers (RTD) in 2-, 3- or 4-wire connections, thermocouples, resistance and voltage inputs. Setting up of the transmitter is done using the communication cable. These small units can be mounted in Pyromation DIN (Form B) connection heads or they can be used for surface mounting by using a 35 mm DIN-rail mounting clip.

TEMPERATURE HEAD TRANSMITTER

Universal head transmitter for resistance thermometers (RTD), thermocouples, resistance and voltage inputs, programmable using a PC, for installation in a sensor head (Form B)

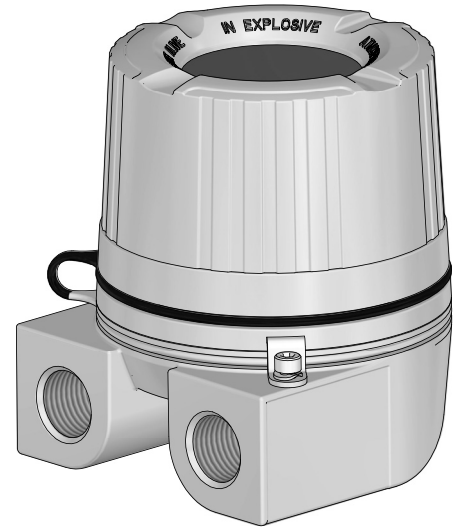
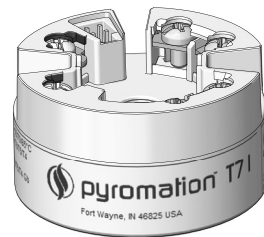
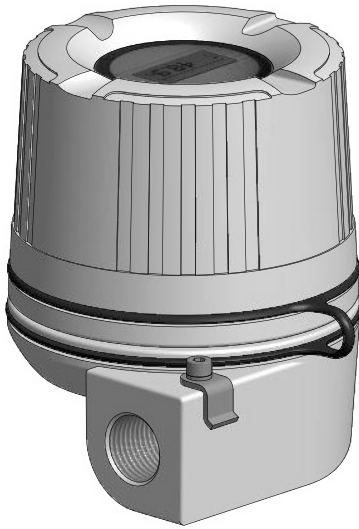

Features and Benefits

- PC programmable temperature transmitter for converting various input signals into an scalable (4 to 20) mA analog output signal
- Universally programmable for Input types:
 - Resistance thermometer (RTD)
 - Thermocouple (TC)
 - Resistance (Ω)
 - Voltage (mV)
- High Accuracy in total ambient temperature range
- Fault signal on sensor break or short circuit
- Optional Display with direct mount or remote mount housing
- **CE** Marked meets EMC and ROHS Directive
- **CS** For use in ordinary locations for US and Canada meets 61010-1
- Galvanic isolation
- **IS** Intrinsically safe for hazardous locations
 - Ex ia IIC T6...T4Ga
 - Ex ia IIC T6...T4Gb
 - Class I, Zone 0, AEx ia IIC T6...T4Ga
 - Class I, Zone 1, AEx ia IIC T6...T4Gb
 - IS Class I, Division 1, Groups A,B,C,D T6...T4
 - IS Class I, Division 2, Groups A,B,C,D T6...T4
- **ES** Explosion-proof for hazardous locations
 - With 79 enclosure
 - Class I, Division 1, Groups A,B,C,D; T6...T4
 - Class II, Division 1, Groups E, F, G; Class III

Authorized Distributor:

WESCHLER INSTRUMENTS

phone: 800-903-9870 440-378-6580

fax: 800-903-9590 440-238-0660

www.weschler.com info@weschler.com



INPUT

Complete Specifications are listed in the T71 Manual available at www.pyromation.com/TechInfo/Docs/asp.aspx or scan QR code



Resistance Thermometer (RTD)

AS PER STANDARD	DESIGNATION	MEASURING RANGE LIMITS	MINIMUM SPAN
IEC 60751	Pt100 ($\alpha = 0.00385 \text{ } ^\circ\text{C}^{-1}$)	(-200 to 850) °C [-328 to 1562] °F	(10) °C [18] °F
	Pt1000 ($\alpha = 0.00385 \text{ } ^\circ\text{C}^{-1}$)	(-200 to 250) °C [-328 to 482] °F	(10) °C [18] °F
JIS C1604:1984	Pt100 ($\alpha = 0.00392 \text{ } ^\circ\text{C}^{-1}$)	(-200 to 510) °C [-328 to 950] °F	(10) °C [18] °F
	Pt100 (Callendar van Dusen)	The measuring range limits are specified by entering the limit values that depend on the coefficients A to C and R0.	(10) °C [18] °F
Connection Type: 2-, 3- or 4-wire connection, sensor current: $\leq 0.3 \text{ mA}$ With 2-wire circuit, compensation of wire resistance possible (0 to 30 Ω) With 3- and 4-wire connection, sensor wire resistance up to maximum 50 Ω per wire			
Resistance Transmitter	Resistance Ω	(10 to 400) Ω (10 to 2000) Ω	10 Ω 10 Ω

Thermocouples (TC)

AS PER STANDARD	DESIGNATION	MEASURING RANGE LIMITS	RECOMMENDED TEMPERATURE RANGE	MINIMUM SPAN
IEC 60584, Part 1 ASTM E230	B (PtRh30-PtRh6)	(40 to 1820) °C [104 to 3308] °F	(500 to 1820) °C [932 to 3308] °F	(50) °C [90 °F]
	E (NiCr-CuNi)	(-250 to 1000) °C [-482 to 1832] °F	(-150 to 1000) °C [-238 to 1832] °F	(50) °C [90 °F]
	J (Fe-CuNi)	(-210 to 1200) °C [-346 to 2192] °F	(-150 to 1200) °C [-238 to 2192] °F	(50) °C [90 °F]
	K (NiCr-Ni)	(-270 to 1372) °C [-454 to 2501] °F	(-150 to 1200) °C [-238 to 2192] °F	(50) °C [90 °F]
	N (NiCrSi-NiSi)	(-270 to 1300) °C [-454 to 2372] °F	(-150 to 1300) °C [-238 to 2372] °F	(50) °C [90 °F]
	R (PtRh13-Pt)	(-50 to 1768) °C [-58 to 3214] °F	(50 to 1768) °C [122 to 3214] °F	(50) °C [90 °F]
	S (PtRh10-Pt)	(-50 to 1768) °C [-58 to 3214] °F	(50 to 1768) °C [122 to 3214] °F	(50) °C [90 °F]
	T (Cu-CuNi)	(-200 to 400) °C [-328 to 752] °F	(-150 to 400) °C [-238 to 752] °F	(50) °C [90 °F]
DIN 43710	U (Cu-CuNi)	(-200 to 600) °C [-328 to 1112] °F	(-150 to 600) °C [-238 to 1112] °F	(50) °C [90 °F]
Internal reference junction (Pt100) External preset value: Configurable value (-40 to 85) °C [-40 to 185] °F Maximum sensor wire resistance 10 k Ω (If the sensor wire resistance is greater than 10 k Ω , an error message is output in accordance with NAMUR NE89.)				
Voltage transmitter (mV)	Millivolt transmitter (mV)	(-20 to 100) mV	-	5 mV

OUTPUT

Output Signal

Analog Output	(4 to 20) mA or (20 to 4) mA (can be inverted)
Transmission as	Temperature linear, resistance linear, voltage linear
Filter 1st	1st order digital filter: (0 to 120) s
Current Consumption	3.6 to 23 mA
-	Minimum Current Consumption 3.5 mA
-	Current Limit $\leq 23 \text{ mA}$
Switch on delay	7 s (during power up $I_a \leq 3.8 \text{ mA}$)
Electronic response time	1 s

Failure Mode per NAMUR NE43

Undershooting measurement range	Linear decrease from 4.0 to 3.8 mA
Exceeding measurement range	Linear increase from 20.0 to 20.5 mA
Sensor breakage/short circuit ^[1]	$\leq 3.6 \text{ mA}$ or $\geq 21.0 \text{ mA}$

Electrical Connection

Supply Voltage ^[1]	Values for non-hazardous areas, protected against polarity reversal: $10 \text{ V} \leq V_{cc} \leq 36 \text{ V}$
Galvanic isolation (In/out)	$\hat{U} = 2 \text{ kV AC}$ for 1 minute (input/output)

[1] Values for hazardous area, see Ex Documentation

ACCURACY

Resistance thermometers (RTD) as per standard

STANDARD	DESIGNATION	MEASURING RANGE	TYPICAL MEASURED ERROR (\pm)
			Value at current output
IEC 60751	Pt100	(0 to 200) °C [32 to 392] °F	(0.10) °C [0.18] °F
	Pt1000		(0.08) °C [0.14] °F
JIS C1604:1984	Pt100		(0.10) °C [0.18] °F
Resistance Ω	10 to 400 Ω	(10 to 200) Ω	(0.06) Ω
	10 to 2000 Ω	(10 to 1000) Ω	(0.32) Ω

Thermocouples (TC) as per standard

STANDARD	DESIGNATION	MEASURING RANGE	TYPICAL MEASURED ERROR (\pm)
			Value at current output
IEC 60584-1, ASTM E230	Type B	(0 to 800) °C [32 to 1472] °F	(1.61) °C [2.9] °F
	Type E		(0.34) °C [0.61] °F
	Type J		(0.39) °C [0.70] °F
	Type K		(0.51) °C [0.92] °F
	Type N		(0.62) °C [1.12] °F
	Type R		(1.43) °C [2.57] °F
	Type S		(1.45) °C [2.61] °F
	Type T	(0 to 300) °C [32 to 572] °F	(0.33) °C [0.59] °F
Voltage (mV)	-20 to 100 mV	(0 to 50) mV	25 μ V

INSTALLATION CONDITIONS

Environment

Ambient temperature	(-40 to 85) °C [-40 to 185] °F (For hazardous areas see EX documentation)
Storage temperature	(-50 to 100) °C [-58 to 212] °F
Climatic class	To EN 60654-1, Class C1
Moisture condensation	Allowable
Shock and Vibration protection	Per DNVGL-CG-0339 and DIN EN 60068-2-27 - (2 to 100) Hz at 4g
EMC immunity (CE conformity)	Interference immunity and interference emission as per EN 61 326-1 (IEC 1326)
Altitude	up to 4000M (4374.5 yards) above sea level
Over voltage	Over voltage category II
Pollution degree	Pollution degree 2

MECHANICAL CONSTRUCTION

Dimensions	<p>Option 36</p>	<p>Option 79</p>	<p>Option 79 Wall Mount P/N #22808</p>
			<p>FITS 1" - 2" OD PIPE Option 79 Pipe Mount P/N #22809</p>
Weight	Approximately 31 ounces		
Materials	Aluminum with Polyester coating, Nema 4x, IP66/67		
Note 1: Series 79 has mounting holes for wall mount or pipe mount bracket			

Display Elements

	<p>Item 1: Displays the TAG</p> <p>Item 2: 'Communication' symbol</p> <p>Item 3: Unit display</p> <p>Item 4: Measured value display</p> <p>Item 5: Value/channel display S1, S2, DT, PV, I, %</p> <p>Item 6: 'Configuration locked' symbol</p> <p>Item 7: Status signals</p>
--	--

MECHANICAL CONSTRUCTION (continued)

Dimensions	<p style="text-align: right;">DIMENSIONS IN INCHES [mm]</p>
Weight	approximately 40 g
Materials	Housing: Polycarbonate • Potting: Polyurethane
Terminals	14 AWG (maximum)

Terminal Connections

	<p>2-Wire</p>	<p>3-Wire</p>	<p>4-Wire</p>

Remote Operation

Configurable parameters	Sensor type and connection type, engineering units (°C/°F), measurement range, internal/external cold junction compensation, cable resistance compensation on 2 wire connection, fault conditioning, output signal (4 to 20) mA or (20 to 4) mA, digital filter (damping), offset, measurement point identification (8 characters), output simulation
-------------------------	---

Approvals

	Unit complies with the legal requirements set forth by the EU regulations.
	For General Purpose use
	No display: I.S. Class I / Division 1 / Groups ABCD Class I, Zone 0 (EPL Ga), IIC Ex ia IIC Ga; AEx ia IIC Ga
	With display: I.S. Class I / Division 2 / Groups ABCD Class I, Zone 1 (EPL Gb), IIC Ex ia IIC Gb; AEx ia IIC Gb
	With 79 Enclosure - XP: Class I, Division 1, Groups A,B,C,D: Class II, Division 1, Groups E,F,G; Class III
	With 79 Enclosure - I.S.: Class I, Division 2, Groups A,B,C,D: NIFW and associated apparatus for Class I, Division 1, Groups A,B,C,D