



## Description

DT-BB Series transducers combine a Hall Effect sensor and a signal conditioner into a single package. This provides higher accuracy, lower wiring costs, easier installation and saves valuable panel space. DT-BB Series are available in split core housing designed for installation on bus bar, or cable, and can be mounted on the conductor or secured to a back panel or to a DIN rail with optional adapters.

## Installation

### For All Versions

Run conductor to be monitored through opening in the sensor, or clamp the sensor over the bus bar.

DT Series transducers work in the same environment as motors, contactors, heaters, pull-boxes, and other electrical enclosures. They can be mounted in any position or hung directly on conductor with the securing clamp screws. Just leave at least one inch distance between sensor and other magnetic devices.

**Split Core Release:** Pry the tab away from the sensor body to open the sensor. After placing the wire or bus bar in the opening, press the hinged portion firmly downward until a definite click is heard and the tab snaps in.

Use the securing screws mounted into extrusions on the top of the sensing aperture to keep the sensor from moving. Be very careful not to damage any insulation over the conductor.

### KEEP SPLIT-CORE SENSORS CLEAN.

Silicone grease is factory applied on the mating surfaces to prevent rust and improve performance. Be careful not to allow grit or dirt onto the grease in the contact area. Operation can be impaired if the mating surfaces do not have good contact. Check visually before closing.

## Single Range

DT-BB Series transducers feature single ranges. The range is factory calibrated, eliminating time consuming and inaccurate field setting of zero or span.

## Output Wiring

Connect control or monitoring wires to the sensor. Use up to 22-14 AWG copper wire rated 75/90°C and tighten terminals to 5-7 inch-pounds torque.

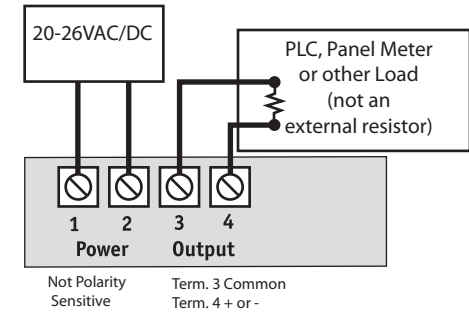

Power and Output are Not Isolated

## Output Signal Polarity Indication

### Bidirectional Output

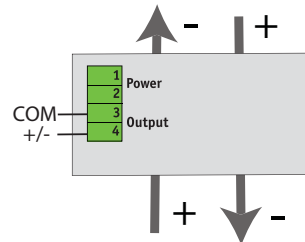
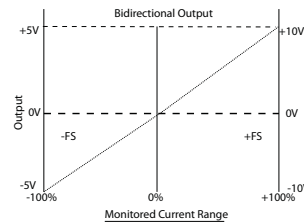

	Current Direction #1		Current Direction #2		
	0-5V	0-10V	0-5V	0-10V	
FS	+5V	+10V	FS	-5V	-10V
1/2 FS	+2.5V	+5V	1/2 FS	-2.5V	-5V
Zero	+0	+0V	Zero	-0V	-0V

Output is positive with current flowing in one direction, and negative with current flowing in the opposite direction. .

## Trouble Shooting

### 1. Output Signal Too Low

- The sensor may have a range that is too high for current being monitored. *Select a sensor with the lower range.*
- Power supply is inadequate. *Check power supply. Make sure it is of sufficient voltage with all loads at maximum. DT Series draw 2.0 VA.*
- Output load too low. *Check output load, be sure it is at least 25K  $\Omega$  for 5VDC, 50K  $\Omega$  for 10 VDC, and less than 500  $\Omega$  for 4-20mA models.*

### 2. Output Signal is always at maximum

- The sensor may have a range that is too low for current being monitored. *Select sensor range based on maximum expected current magnitude.*

### 3. Sensor has no output

- Polarity is not properly matched. *Check and correct wiring polarity*
- Monitored load is not DC or is not on. *Check that the monitored load is DC and that it is actually on.*
- Split Core fitting: The core contact area may be dirty. *Open the sensor and clean the contact area.*