

Specifications

Output Signal	0-5 or 0-10 VDC
Accuracy	1% FS
Frequency Range	DC
Isolation Voltage	3kV (Monitored line to output)
Linearity	0.75% FS
Response Time	500 mS (to 90% of step change)
Repeatability	1% FS
Power Supply	24VDC (19-30 VDC)
Power Consumption	1 VA
Enclosure	UL 94V-0 Flammability rated thermoplastic
Environmental	-20 to 50 deg. C

DT Series DC current transducers are an innovative design hall effect based DC current transducer. With this design, the power needed to operate the sensor is derived from an external DC supply connected in common with the sensor output. This design utilizes three wires rather than four with most other DT models from NK. Perfect for photovoltaic panel monitoring, at the panel, string or array level. Small size allows for placement inside combiner boxes, and the extended temperature range means a lower need for cooling of the control system.

Model Number Key

DTB - 010 - 24D - U - FF

CASE:
FF- Solid Core Front Term

POLARITY:
U- Unipolar

POWER SUPPLY:
24D- 24 VDC

OUTPUT:
005- 0-5 VDC
010 - 0-10 VDC

RANGE
B- 0 to 50 ADC
C- 0 to 100 ADC

SENSOR TYPE:

DT - DC current sensor with analog output.

Know Your Power

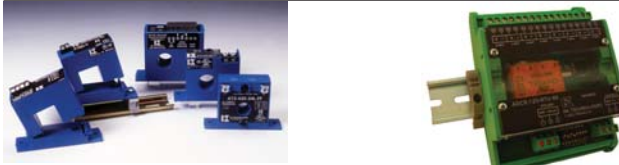

Other NK Technologies Products Include:

DC Current Switches, Ground Fault Sensors
AC & DC Current Switches, Power Transducers
Current & Potential Transformers (CTs&PTs)



NK Technologies

3511 Charter Park Drive, San Jose, CA 95136
800-959-4014 or +1-408-871-7510 Phone
+1-408-871-7515 FAX
sales@nktechnologies.com, www.nktechnologies.com



INSTRUCTIONS



DT 3 Wire SERIES SOLID CORE 0-5 or 0-10 VDC Outputs

Quick "How To" Guide

1. Place wire to be monitored through aperture. Ensure monitored current flow matches arrow on sensor or as noted on figure on reverse side.
2. Mount the sensor.
3. Connect output wiring.
 - A. Use up to 2.5 mm² (14 AWG) copper wires. Tighten terminals to .6 Nm (5 in-lbs) torque.
 - B. For voltage output models, ensure output load is no less than 10K Ω .
4. Connect Power.
 - A. Connect the power supply positive to terminal 1, negative to C
5. Connect the output from term. 2 to the load, use terminal C as a negative common.

Description

DT 3 Wire Series transducers combine a Hall Effect sensor and a signal conditioner into a single package. This provides higher accuracy, lower wiring costs, easier installation and saves valuable panel space. DT Series are available with voltage outputs.

Installation

Place wire to be monitored through sensor aperture. Care should be taken to ensure current flow is in accordance with any directional arrows on sensor and as noted in the figure below:

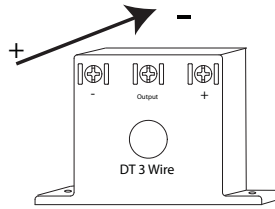

DT Series transducers work in the same environment as motors, contactors, heaters, pull-boxes, and other electrical enclosures. They can be mounted in any position or hung directly on wires with a wire tie. For optimal performance, ensure unit has been energized for a period of 20 minutes prior to sensing operation.

0-5 or 0-10 VDC Output:

The output signal is powered by an external source. The connection diagram on the right. Minimum impedance for stated accuracy is 10K Ω .

Current Direction:

Ensure the direction of monitored current is the same as the direction shown on the diagram. The unit will not operate properly if the current is opposite the direction of the arrow.

Wiring & Mounting Information

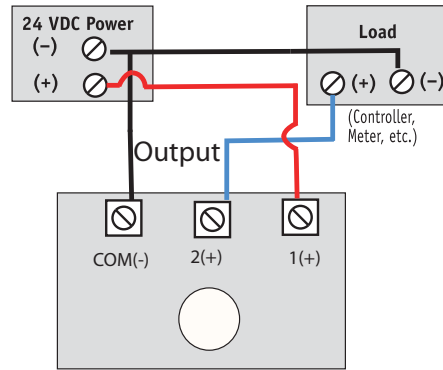

Connect the negative from the power supply to the negative of the load (panel meter, PLC, etc.). Connect the positive from the power supply to the positive terminal (1) of the sensor. Connect the output terminal (2) of the sensor to the positive or input of the load.

Connect the common (C) terminal to the negative of the power supply and the load.

Range Select

DT Series transducers feature factory calibrated ranges.

1. Determine the normal operating amperage of moni-

tored circuit

2. Select the model with a range that is equal to or slightly higher than the normal operating amperage.

Trouble Shooting

1. Output Signal Too Low

- A. There may be current present, but lower than expected. *Check primary current with a meter.*
- B. Power supply is inadequate. *Check power supply. Make sure it is of sufficient voltage with all loads at maximum. DT Series consumes less than 1 VA.*
- C. Output load too low. *Check output load, be sure it is at least 10K Ω .*

2. Output Signal is always at maximum

- A. There may be current of a higher level than the sensor range. *Replace with a sensor having a higher range.*

3. Sensor has no output

- A. Polarity is not properly matched. *Check and correct wiring polarity.*
- B. Monitored load is not DC or is not on. *Check that the monitored load is DC and that it is actually on.*

Unipolar Output

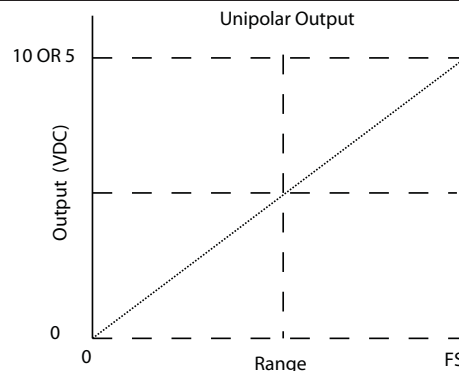

Output with current in the direction of the arrow only.

If the requirement is to monitor the current flowing in both directions, select the DT four wire series bipolar output, a bidirectional output or split core unipolar output from NK Technologies web site.