

## Specifications

Output Signal	0-5VDC or 0-10VDC proportional to the RMS Current
Output Limit	112% of standard output range maximum value
Frequency Range	10-400 Hz
Response Time ( 90% of step change)	600mS
Accuracy	1.0% Full Scale Split Core
Loading	100K $\Omega$ Minimum
Power Supply	24VDC See "Output Wiring" section.
Isolation Voltage	UL listed to 1,270VAC, tested to 5kV
Case	UL 94V-0 Flammability rated thermoplastic
Environmental	-20 to 50 Deg. C, (-4-122 Deg F) 0-95% RH, non-condensing
Listing	Designed to meet CE, UL 508 Industrial Control Equipment

## Input Maximums

### MAXIMUM INPUT AMPS

<u>MODEL</u>	<u>RANGE</u>	<u>6 SEC.</u>	<u>1 SEC.</u>
ATPR0	0-2A	125	250
ATPR0	0-5A	125	250
ATPR1	0-10A	125	250
ATPR1	0-20A	150	300
ATPR1	0-50A	215	400
ATPR2	0-100A	300	600
ATPR2	0-150A	450	800
ATPR2	0-200A	500	1,000

## Model Number Key

**ATPR 1 - 010 - 24D - SP**

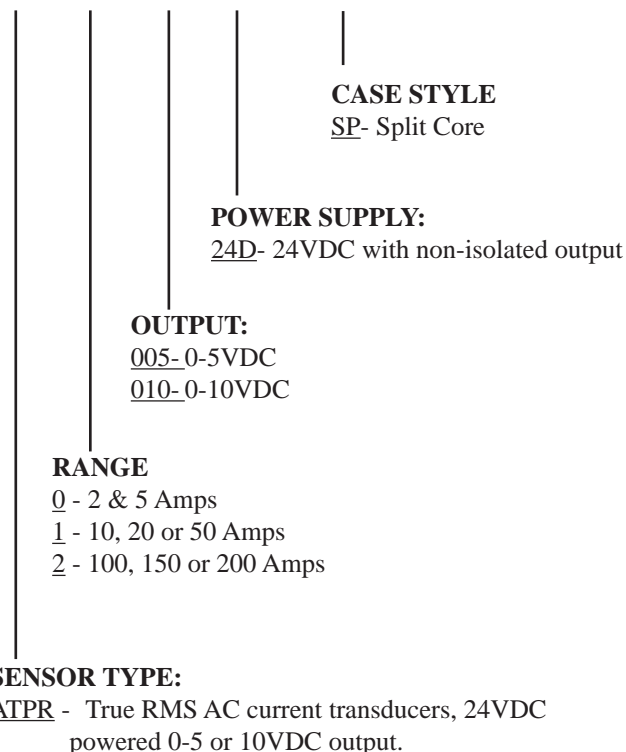

## Know Your Power



### Other NK Technologies Products Include:

AC & DC Current Transducers  
 AC & DC Current Operated Switches  
 1 $\phi$  & 3 $\phi$  Power Transducers  
 Current & Potential Transformers (CTs&PTs)



## NK Technologies

3511 Charter Park Drive, San Jose CA 95136  
 800-959-4014 or +1-408-871-7510 Phone  
 +1-408-871-7515 FAX  
 sales@nktechnologies.com, www.nktechnologies.com



# INSTRUCTIONS



## ATPR SERIES Powered RMS AC Current Transducers 0-200A Input Maximum Range 0-5VDC or 0-10VDC Output

### Quick "How To" Guide

1. Run the wire you are monitoring through aperture.
2. Mount the sensor to a surface if needed.
3. Connect output wiring.
  - A. Use up to 14AWG copper wires.
  - B. 0-5/10 VDC Models: Make sure output load is at least 100 K $\Omega$  to achieve stated accuracy
4. Chose correct range by positioning the Range Jumper.
5. Energize the sensor by connecting 24 VDC to the power supply terminals.

## Description

The ATPR Series powered AC current transducers combine a current transformer and signal conditioning electronics in a single package for use in applications where the current wave is distorted or non-sinusoidal. The combination of these devices results in a single unit with higher accuracy, fewer individual terminations, and a space-saving simplified installation.

ATPR Series transducers are available in solid- or split-core enclosures and with 0-5VDC or 0-10VDC analog outputs. Custom input and output ranges may also be available; please consult with the factory. ATPR Series transducers are RMS responding and intended for use in variable speed applications, with distorted waveforms, but will also be accurate when used to monitor sinusoidal current wave shapes.

## Installation

1. Place wire in which current is to be monitored through aperture of ATPR unit.
2. Mount ATPR unit using screw holes in mounting base unit, taking care maintain at least one-inch clearance in all directions between the sensor and other magnetic devices for proper operation. *Note: The transducer is not directionally sensitive and can be mounted in any position or hung directly on wiring with the use of wire ties.*
3. For –SP versions (split-core enclosures) only: Press the tab in the direction as shown to open the sensor. After placing the wire in the opening, press the hinged portion firmly downward until a definite click is heard and the tab pops out fully.

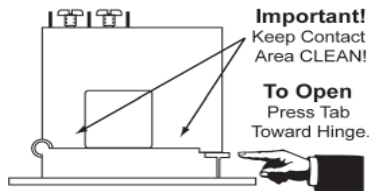

### KEEP SPLIT-CORE SENSORS CLEAN.

Silicone grease is factory applied on the mating surfaces to prevent rust and improve performance. Be careful not to allow grit or dirt onto the grease in the contact area. Operation can be impaired if the mating surfaces do not have good contact. Check visually before closing.

## Output Wiring

Connect control or monitoring wires to the sensor. Use up to 14 AWG copper wire and tighten terminals to 4 inch-pounds torque.

### Connection Notes:

- Deadfront captive screw terminals
- 14-22 AWG solid or stranded.
- Observe Polarity

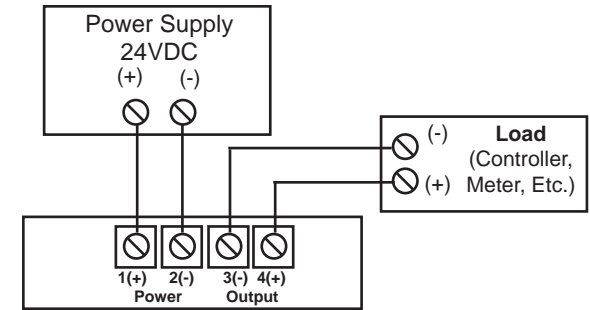

## Range Select

ATPR Series transducers feature field selectable ranges. The ranges are factory calibrated, eliminating time consuming and inaccurate field setting of zero or span.

1. Determine the normal operating amperage of your monitored circuit.
2. Select the range that is equal to or slightly higher than the normal operating amperage.
3. Place the range jumper in the appropriate position.

## Trouble Shooting, 0-5 and 0-10 VDC Models

### 1. Sensor has no output

- A. Polarity is not properly matched. *Check and correct wiring polarity*
- B. Monitored load is not AC or is not on. *Check that the monitored load is AC and that it is actually on.*
- C. Split Core models: The core contact area may be dirty. *Open the sensor and clean the contact area.*

### 2. Output Signal Too Low

- A. The jumper may be set in a range that is too high for current being monitored. *Move jumper to the correct range.*
- B. Output load too low *Check output load, be sure it is at least 100K Ω.*
- C. Monitored current is below minimum required. *Loop the monitored wire several times through the aperture*

*until the “sensed” current rises above minimum. Sensed Amps = (Actual Amps) x (Number of Loops). Count loops on the inside of the aperture.*

### 3. Output Signal is always at maximum

- A. The jumper may be set in a range that is too low for current being monitored. *Move jumper to the correct range*

### 4. Output does not match the current measured with a hand meter:

- A. The ATPR sensors are producing a signal proportional to the RMS current, and not the average current.
- B. Check that the test meter is RMS or the two readings will not match.

Note that True RMS current transducers will be accurate if the wave shape is sinusoidal or distorted.