

POWER SERIES ^{Plus}

3 in 1 AC Current

Digital Switchboard Meter

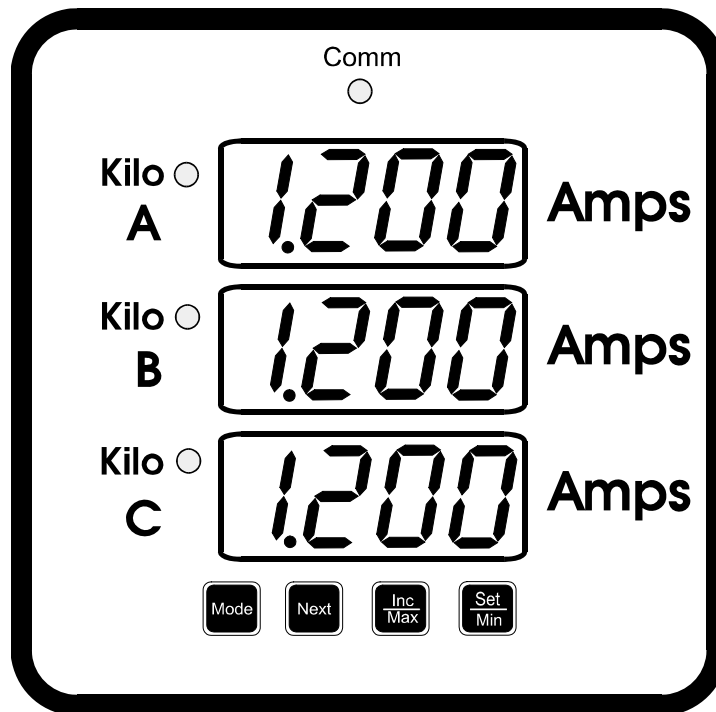

User's Manual

General Description

The POWER SERIES Plus digital switchboard meters incorporate the latest DSP microprocessor technology. Careful and thoughtful design has resulted in a family of user-friendly, field-adjustable meters.

When ordering the 2493 meter, the following options are available:

- AC Measuring Function(s): Volts, Amps, Watts, VARs, Power Factor, and/or Frequency.
- Input Range: 0-150, 0-300V, 0-600V, 0-1 A, 0-5 A, 40-70 Hz, 300-500 Hz
- Wiring Configuration: 1P2W, 1P3W, 3P3W, 3P4W, 3P4W 2½ element
- Analog Output Type: 0 to 1mADC, 4 to 20 mADC, or none
- Power Supply: Universal Power Supply (85VAC-265VAC/110VDC-340VDC), 24VDC, or 48VDC.
- Communications: MODBUS comm., ASCII protocol or no comm.

The meter display and output scaling are completely field-adjustable from the front panel. The meter does not need to be re-calibrated after adjusting the display or the output scaling. There are no internal parts that the user needs to service or adjust. When a **POWER SERIES Plus** meter leaves the factory it will be calibrated to meet or exceed its published specifications.



SAFETY NOTE: There are no field-serviceable parts in the unit. If the unit is disassembled for any reason both auxiliary power and all inputs must be de-energized.

LIMITED WARRANTY

This meter has been delivered to you after strict quality control and inspection. Weschler Instruments warrants its Equipment to meet applicable specifications and to be free from defects in material and workmanship for a period of one (1) year from date of shipment to the original Purchaser. Upon receipt of prompt notice from Purchaser, referencing the order number and detailing the claimed non-conformity or defect, Seller shall, at its option, repair or replace the Equipment. Equipment returned to Seller will only be accepted with a Returned Material Authorization (RMA) number issued by Seller or one of its authorized representatives. Inbound shipping charges to Seller's factory in Cleveland OH, or other designated facility, are the responsibility of Purchaser. Normal shipping charges for the return to Purchaser of repaired or replacement Equipment shall be the responsibility of the Seller (North American points only).

Repair or replacement of the Equipment in the manner described above is the exclusive warranty remedy and shall constitute complete fulfillment of all Seller's liabilities for breach of this warranty. The Seller assumes no responsibility hereunder for any equipment damage or failure caused by improper installation, operation and maintenance of the Equipment, or normal wear and tear on disposable or consumable parts. This warranty shall be void in the event of unauthorized modification or servicing of the Equipment.

The foregoing warranty is exclusive and in lieu of any other warranties of quality, whether expressed or implied (including any warranty of merchantability or fitness for a particular purpose). In no event shall Seller be liable hereunder for any special, indirect, incidental or consequential damages including the loss of revenue or production.

3 in 1 AC Current Specifications

PRODUCT FUNCTION:	AC Amps, 3 Phases
ACCURACY:	$\pm 0.2\%$ of Reading $\pm 0.1\%$ of Full Scale
DISPLAY UPDATE RATE:	Channel A: 80 milliseconds Channel B & C: 160 milliseconds
OPERATING TEMPERATURE RANGE:	-20 to +60 °Celsius
STORAGE TEMPERATURE RANGE:	-40 to +85 °Celsius
INPUT RANGES:	0-1 Amp AC or 0-5 Amp AC
CURRENT TRANSFORMER RATIO RANGE:	1:1 through 9999:1
ANALOG OUTPUTS (Optional):	0 – 1 mADC, 10 VDC compliance into 10 k Ω 4 – 20 mADC, 15 VDC compliance into 750 Ω
ANALOG OUTPUT RESPONSE RATE:	within $\pm 1\%$ of final value within 1.0 second
ISOLATION:	
Input/Output and Case:	2500 VAC
Output to Aux. Power:	2000 VAC or 500 DC for DC-powered option
Aux. Power to Case:	2000 VAC or 500 DC for DC-powered option
Output to Case:	1000 VAC

CONFIGURING THE 2493 POWER SERIES^{Plus} METER

The new triple-display POWER SERIES^{Plus} can be configured for voltage and current inputs from instrument transformers, as well as analog outputs, Modbus or ASCII protocol Communications parameters and a rolling average display.

All set-up functions can be performed using the four push-buttons on the front panel (see below) or via ASCII or Modbus communications. You can also use the buttons to display the minimum and maximum readings and to change the display from phase to phase.



This button starts all operations. When viewing or changing settings it is used to back out of a mode.



This button, when changing settings, it moves between settings or between digits.



This button will increment the value being changed. It is also used to display Max readings.



This button, when changing settings, is used to select a mode, save it, and then move to the next mode in the sequence. It is also used to display Min readings.

All button operations are begun with the **Mode** button.

To see the Min or Max, push the **Mode** button and then the button of the reading you want to see – **Min** or **Max**. The values will display for ten (10) seconds before reverting to the normal display. If you want to reset the values, push the **Min** or **Max** button again before the 10 seconds has expired.

To view the configuration settings, press **Mode** twice (**Mode – Mode**) and then press **Set**. The first setting – the Current Transformer (CT) ratio - will be displayed.. To see the other settings, press **Next**. You can scroll through all the settings by pressing **Next**. To go back to normal operations, press **Mode**. To change the setting being shown, press **Set**. See the specific sections on the following pages for details on how to change the settings. Once a setting is changed it will advance to the next setting. At any point while changing settings, pressing **Mode** will exit the mode without changing anything.

KEY MAP

This flowchart illustrates the operation of the **POWER SERIES^{Plus}** meter using the push-keys on the front panel.

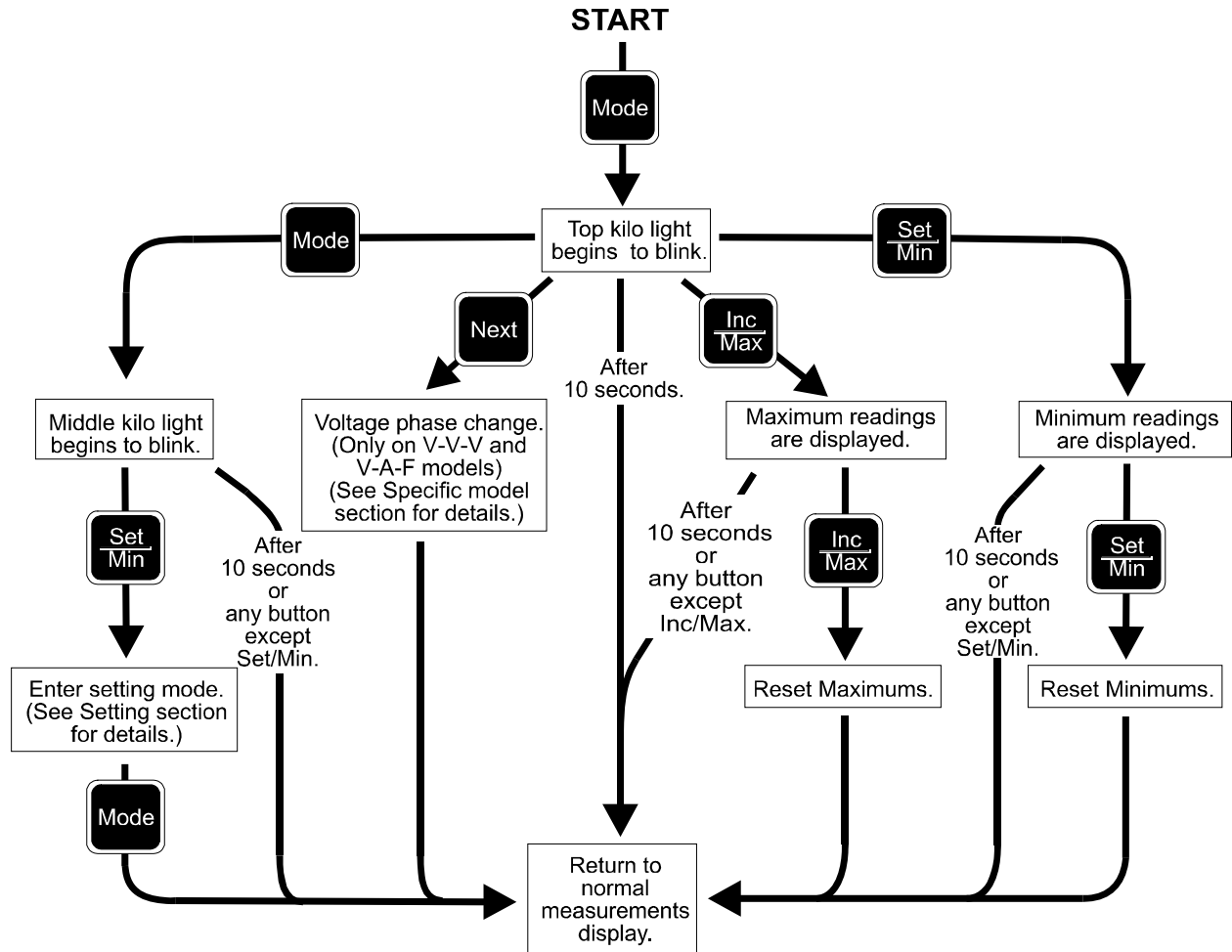

SETTING MODE

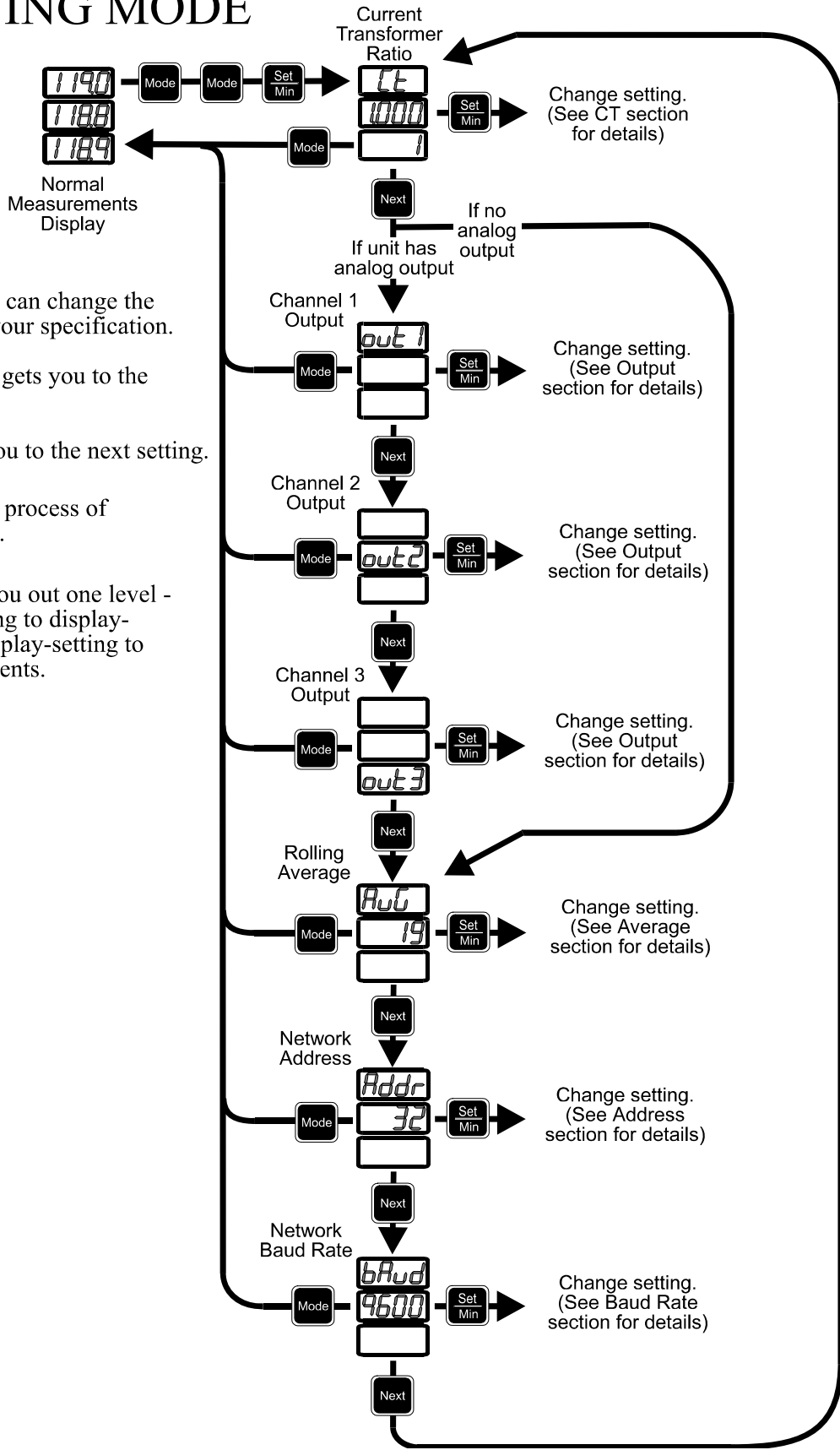

Here is where you can change the meter settings to your specification.

Mode-Mode-Set gets you to the first setting.

Next will move you to the next setting.

Set will begin the process of changing a setting.

Mode will back you out one level - from change-setting to display-setting or from display-setting to display-measurements.

CHANGING THE CURRENT TRANSFORMER (CT) RATIO SETTING

When you reach the CT setting, the primary value will be displayed in the middle row and the secondary value will be displayed in the bottom row. Press **Set** and the first digit of the primary value will begin blinking. You can increment the value of this digit by pressing **Inc**. Once a digit has reached 9 (nine) it will then go to 0 (zero). To move to the next digit press **Next**. You can return to the first digit by pressing **Next** while the last digit is blinking.

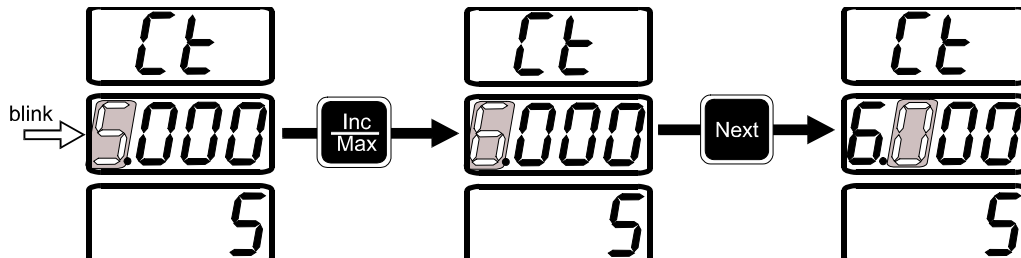

When you have the digits as you want them, press **Set**. The decimal point will now be blinking. You can then move the decimal point to the right by pressing **Inc**. Once it has reached the last position it will jump to the first position on the next **Inc**.

Pressing **Set** again will bring you to the Multiplier (Kilo) setting. In the leftmost digit you will see a blinking 'K' and if the multiplier light is on, it will also blink. You can change the setting by pressing **Inc**.

If you have a 5 Amp unit, the next time you press **Set** the value of the secondary will blink. To change the value, press **Inc**. There are only two choices: 1 or 5.

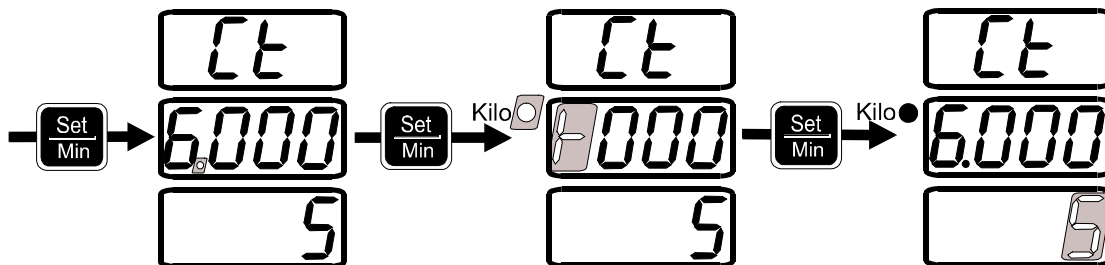

If you have a 1 Amp unit, or you have set the secondary on a 5 Amp unit, pressing **Set** will now move you to the Confirm mode. All values will blink. If the values are correct press **Set** one last time to save them and move on to the Analog Output settings. Pressing **Mode** at this time or at any other step in the process will restore the old CT settings.

The CT primary value can be set to any value between 1.000 and 49995 (5 Amps X 9999 ratio). If it is not in this range you get the error "ErrH" (Too High) or "ErrL" (Too Low) when you try to advance to the secondary. The ratio of the Primary and Secondary must be between 1.000 and 5000. You will get "ErrH" or "ErrL" if you try to advance to Confirm mode with an incorrect ratio.

If you try to save a ratio value that exceeds the precision of the unit, that value will be automatically rounded off. For example, setting the CT to a ratio of 5.367 to 5 results in a value of 1.0734. The unit will round this to 1.073, and in the future display the ratio as 5.365 to 5. Setting the secondary to 1 will always avoid this.

CHANGING THE ROLLING AVERAGE SETTING

The rolling average causes the displayed value to be an average of the number of samples to which this parameter is set. Increasing this setting will reduce digit bounce, but will slow the display response time. The analog output response time is not affected by this setting.

When you reach the Average setting, press **Set** and the first digit will begin blinking.

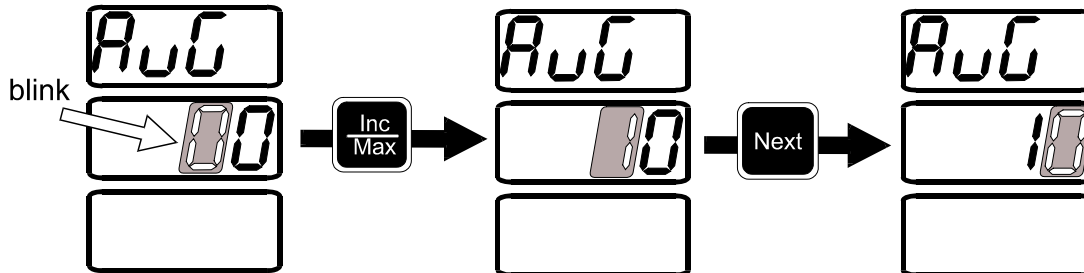

To increment the value of the digit, press **Inc**. Once a digit has reached 9 (nine), it will then go to 0 (zero). To move to the second digit press **Next**. To return to the first digit press **Next** again. When you have set the desired value, press **Set**. Both digits will blink, showing you are now in Confirm mode. If the value is correct press **Set** one more time to save the value and move on to the Address setting. Pressing **Mode** at any time before this will restore the old setting.

The average can be set to any value from 0 to 29.

CHANGING THE NETWORK ADDRESS SETTING

The Address setting is changed in exactly the same way as the Average setting.

The address can be set to any value from 01 to 32. Please make sure that no two units have the same address. If this occurs neither unit will be able to communicate.

After saving the value you will move to the Baud Rate setting.

CHANGING THE BAUD RATE SETTING

When you reach the setting, press **Set** and the whole value will begin blinking.

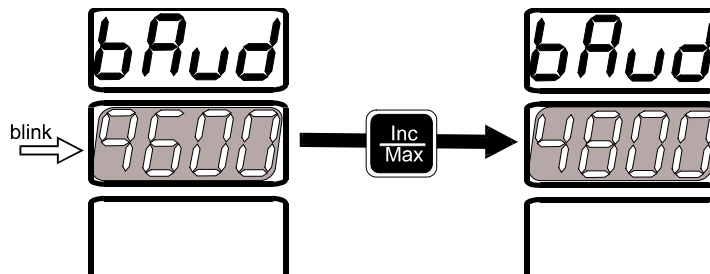

To change it to the next choice, press **Inc**. You can scroll through all the choices with the **Inc** key. Those choices are 9600 (default), 4800, 2400 and 1200. When you have reached the desired choice, press **Set**. The new setting will be saved and the unit will proceed to the next mode.

Analog Output Scaling

The **POWER SERIES^{Plus}** has the option of analog output, which can provide an analog signal relative to the input of the meter. The relationship between the input and the output can be scaled by the user using the front panel. Analog Output 1 is always proportional to the value shown on the first (top) display. Output 2 is always proportional to the middle display, and Output 3 will always be proportional to the bottom display.

A 5 Amp ammeter with 0 to 1 milliamp output, for example, has the following default settings:

CT ratio: 1 to 1

Analog Output LO: 0 Amps

Analog Output HI: 5 Amps

The LO is the input value at which the output will be 0 mA. The HI is the input value at which the output will be 1 mA. The charts at right show the relationship of input and output.

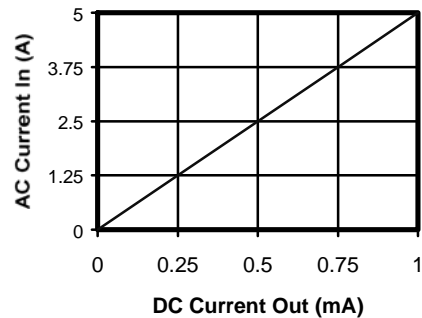

When the settings are changed to:

CT ratio: 1 to 1

LO: 1 Amp

HI: 4 Amps

The new relationship of input and output is shown at right.

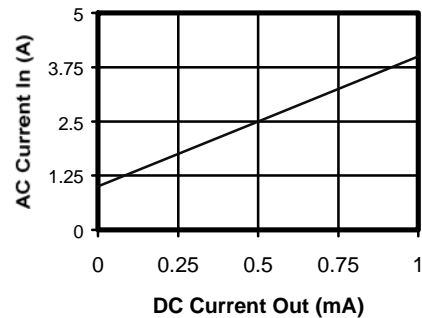

Next the CT ratio is changed to 2 to 1 (2:1). **Note** that the HI and LO automatically change to match the new ratio whenever the CT ratio is changed. So now the settings are

CT ratio: 2 to 1

LO: 2 Amps

HI: 8 Amps

And the relationship is shown at right.

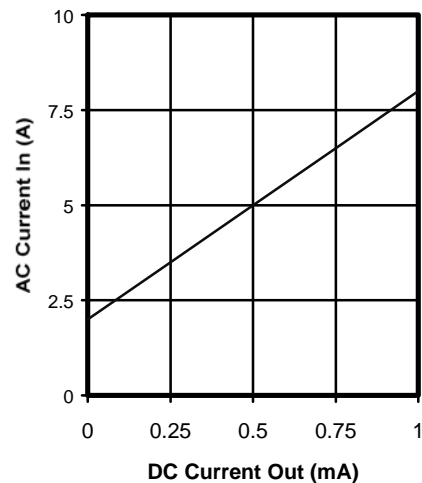

CHANGING THE ANALOG OUTPUT SETTINGS

When you reach the 'out1' (or 'out2' or 'out3') display, press **Set** and the value of HI will be displayed. Pressing **Set** again will cause the first digit to begin blinking.

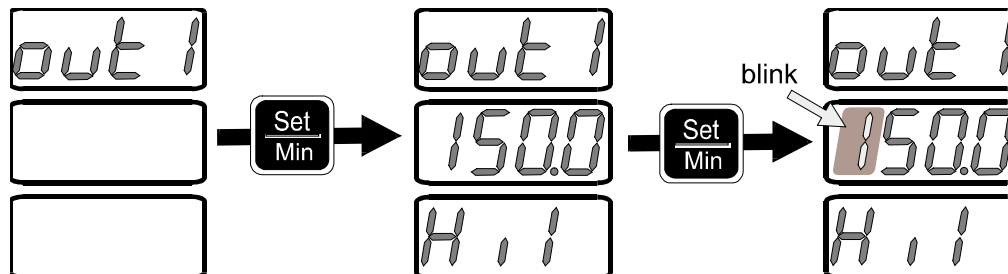

To move to the next digit press **Next**. **Next** will move you through all four digits and back to the first one, if necessary. You can increment the value of the blinking digit by pressing **Inc**. Once a digit has reached 9 (nine) it will go to 0 (zero) on the next press of **Inc**.

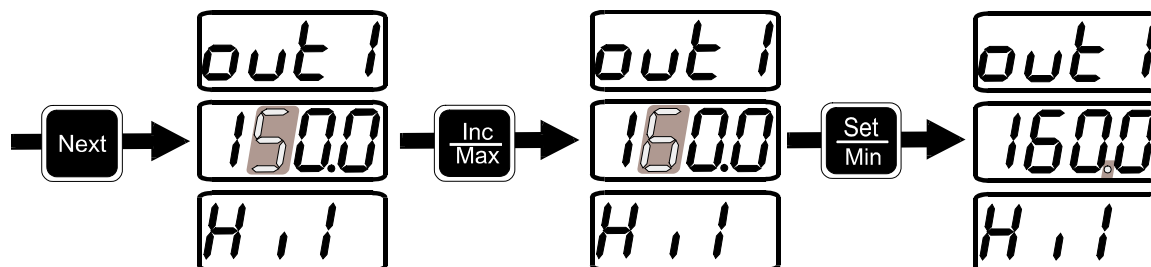

When you have set the digits as you want them, press **Set**. The decimal point will now be blinking. You can then move the decimal point to the right by pressing **Inc**. Once it has reached the last position it will jump to the first position on the next press of **Inc**.

Pressing **Set** again will bring you to the Multiplier (Kilo) setting. In the leftmost digit you will see a blinking 'K' and if the multiplier light is on it will also blink. You can change the setting by pressing **Inc**.

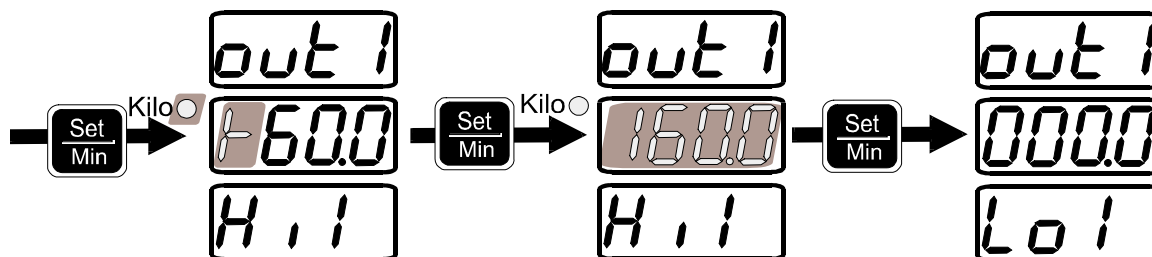

Pressing **Set** will now move you to the HI Confirm mode. The whole value will blink. If the value is correct press **Set** one last time to move on to the LO setting. Pressing **Mode** at this time or at any other step in the process will restore the old HI setting.

Even if you do not want to change the LO setting, you still must go through the steps in LO to save changes that were made to the HI value. Nothing is stored in memory until you are in the LO setting Confirm mode and you press **Set**.

The LO value is changed in the same way as the HI value: First digits, then the decimal point, then the multiplier, and finally the Confirm mode. In Confirm mode, with all the digits blinking, a press of the **Set** button will save all the changes and move you to the next setting.

Note that the output settings have a precision of four (4) digits only. When the CT ratio is large, this will result in rounding if you try to set a value too precisely. For example: If a 5 Amp meter has a CT ratio of 1000:1, then the output settings must be in units of 100. Trying to set a value to 124 or another value not divisible by 100 will result in the value being rounded to the nearest 100's.

The following values apply to the POWER SERIES^{Plus} Ammeters:

Model	Default LO	Minimum LO	Default HI	Maximum HI	Minimum Span
1 Amps	0.0	0.0	1.0	1.8	0.5
5 Amps	0.0	0.0	5.0	9.0	2.5

The above values are without any scaling by the CT ratio. If the CT ratio is greater than 1 to 1, than the output setting values above must be multiplied by the CT ratio. For example, if the CT ratio is changed to 3 to 1, then all the values in the chart above will be multiplied by 3.

You cannot set a value lower than the minimum LO or higher than the maximum HI.

The span between the LO and HI must not be smaller than the minimum span. So with a 5 Amp Ammeter, you could set the LO to 0 and the HI to 2.5. Or you could set the LO to 1.5 and the HI to 4.0. But you could not set the LO to 1.0 and the high to 3.0. 3.0 minus 1.0 is less than 2.5.

If a value is too low you will get the error "**ErrL**". If the value is too high you will see the message "**ErrH**". If the span is not big enough the message is "**ErrS**".

If the input is greater than the HI setting the output will match it until it reaches the limit of the unit. For a 0-1mA unit that limit is 1.06mA. For a 4-20mA unit that limit is 20.96mA. Likewise, if you set LO to 1 Amp, for example, and the input dropped below that, the lower end of the output is limited to 3.04mA for a 4-20mA unit. A 0-1mA unit can never go below 0mA.

Connection Diagrams



All circuits should be de-energized when making connections to the rear terminal block.

PS+ is the positive Power Supply connection
(line voltage for AC supplies).
PS- is the negative Power Supply connection
(neutral for AC supplies).

COM is RS-485 communications.

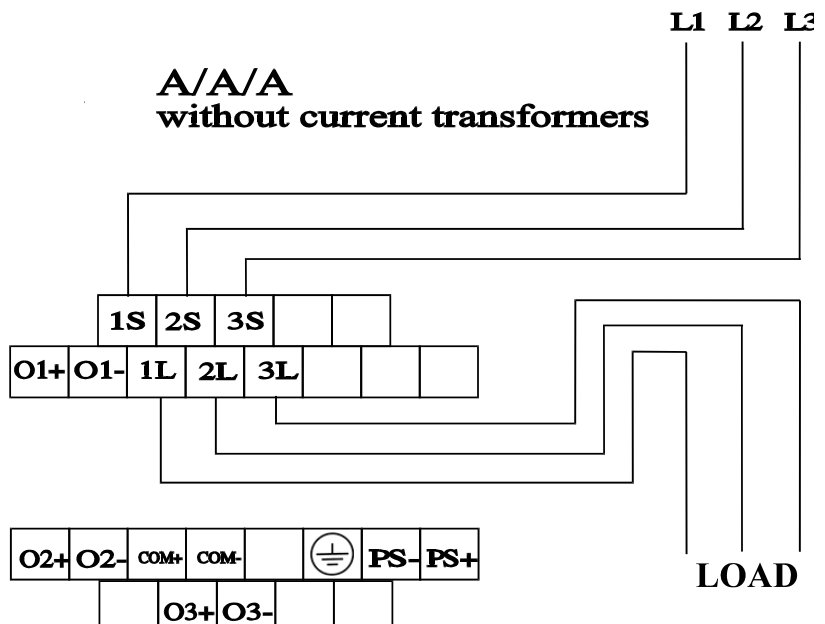
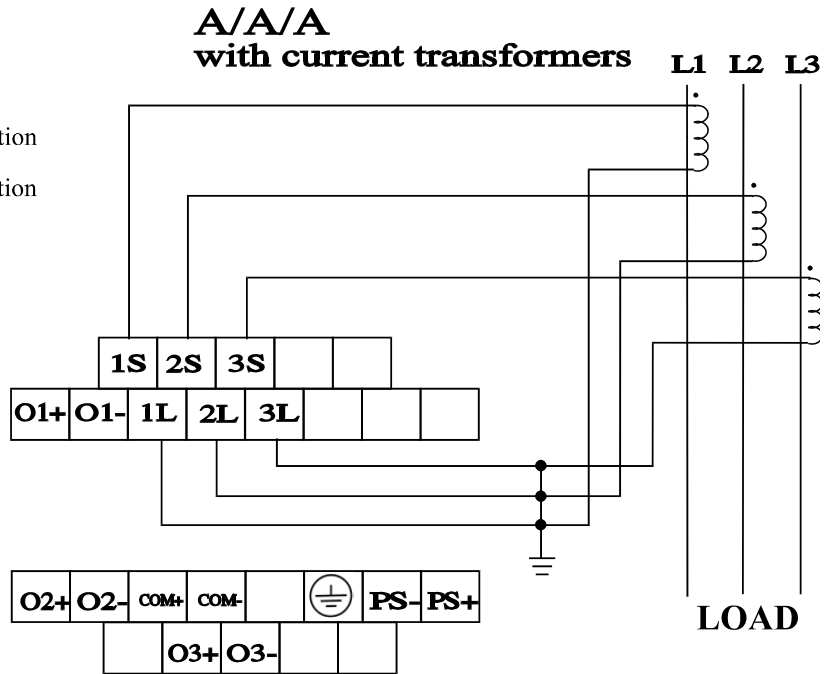

Analog Outputs are assigned as follows:

- O1 - Phase A
- O2 - Phase B
- O3 - Phase C

Mounting and Outline

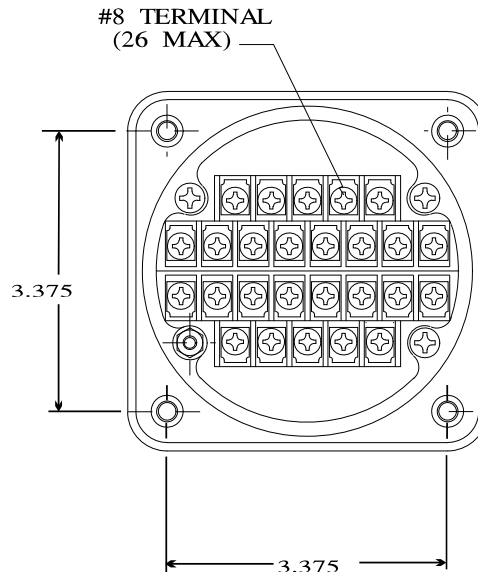
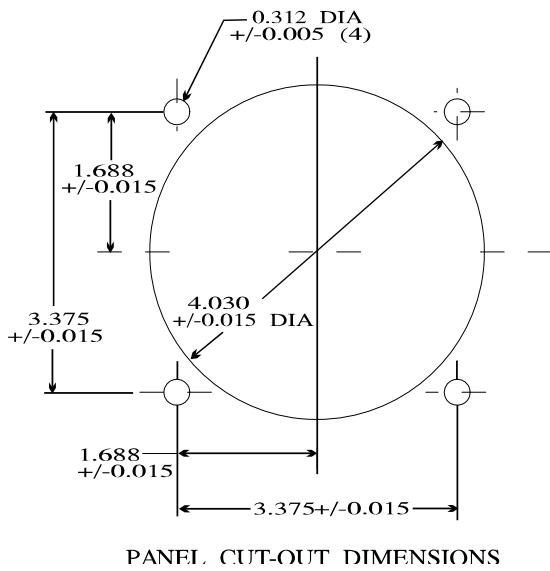
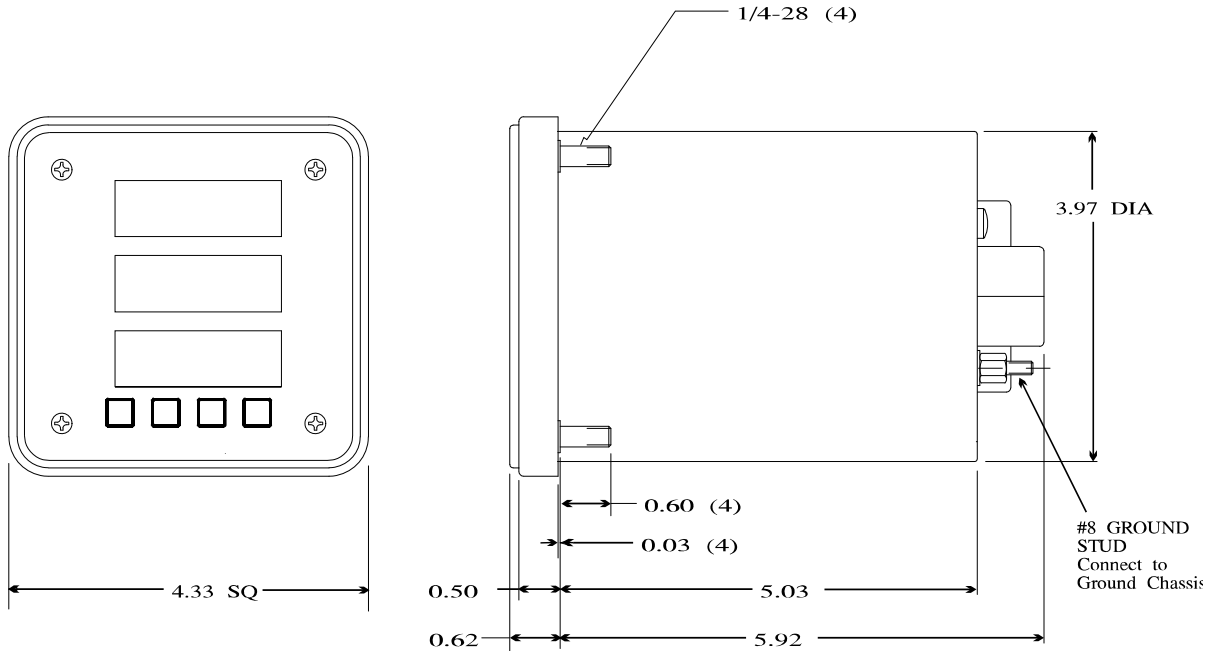

WESCHLER INSTRUMENTS
 16900 Foltz Pkwy
 Cleveland OH 44149 USA

800-903-9870
 info@weschler.com
 www.weschler.com