

PXF9 is an extremely compact temperature controller which has 96 x 96 mm front panel with a large, white LCD and 58-mm depth behind panel.

Developed as a successor to the standard model PXR, PXF4 features fast sampling speed (50 ms) equal to PXH, highly accurate input indication, and universal input, in addition to various functions of PXG, while achieving a competitive price.

Equipped with multiple input/output and sophisticated control functions, PXF4 serves as a suitable temperature controller for a wide range of use.

FEATURES

- Enhanced control performance which makes PXF suitable for a wide range of application
 - Fast sampling speed of 50 ms (cf. PXH: 50 ms, PXR: 500 ms)
 - Improved input indication accuracy
For example: indication accuracy when measuring around 0.0°C by using type K thermocouple of which measuring range 0.0 to 400.0°C: ±1.1°C (cf. PXR: ±3.1°C)
 - Freely configurable control cycle (100 ms to 99 s)
 - Control method selectable among 7 types (ON/OFF control, PID control, fuzzy PID control, self-tuning control, PID2 control, 2-degrees-of-freedom PID control, motorized valve control (with position feedback input))
- Any type of input can be accepted
 - Universal input is supported (thermocouple, RTD, voltage, current)
 - Control output is selectable among 4 types (Relay contact, SSR drive, current linear, voltage linear)
The following optional functions can be incorporated:
 - Up to 3 digital inputs and 5 digital outputs
 - Remote SV input, analog re-transmission output
 - Motorized valve control output (with position feedback input)
 - Current monitoring using CT
- Easy-to-see clear display and user-friendly interface
 - Wide viewing angle, high luminance white LED backlit LCD
 - Large PV display (with character height of 26 mm which is the highest in the market)
 - Easy-to-distinguish parameter display with screen numbers
 - Easy-to-identify 11 segment alphanumeric display
 - Digit select key for easier value-setting (5 keys)
- Most compact design in the market
 - Approx. 30% reduction in size compared to conventional models.
(58 mm depth behind panel)



- A variety of functions extending the possibility of temperature controller
 - 64 steps ramp/soak function
 - 8 PID setting pallets, 8 SV pallets, zone PID facilitate frequent change of control conditions
 - Loader interface provided as standard (Power can be supplied via loader cable. Loader software is available from our HP for free of charge)
 - RS485 communication (optional) capable of cooperative operation, programless communication

SPECIFICATIONS

1. General specifications

Power supply:

100 V (-15%) to 240 V (+10%) AC, 50/60 Hz;
24 V (±10%) DC/AC

Power consumption:

13 VA MAX. (100 to 240 V AC), 8 VA MAX. (24 V DC/AC)

Insulation resistance:

20 MΩ or more (at 500 V DC)

Withstand voltage:

Power source ↔ all terminals: 1500 V AC for 1 min
Relay contact output ↔ all terminals: 1500 V AC for 1 min
Between others 500 V AC for 1 min

2. Input section

2.1 Process value input

Number of input: 1

Input setting:

Programmable scale

Input signal: See Table 1

(Universal input: thermocouple, RTD, voltage, current)

Standard measurement range and input type:

See Table 1

Indication accuracy (at Ta = 23°C):

- Thermocouple input: either $\pm 1^\circ\text{C} \pm 1$ digit or $\pm 0.3\% \pm 1$ digit of indicated value, whichever is larger

*except:

- Thermocouple B: 0 to 400°C: no accuracy assurance
- Thermocouple R: 0 to 500°C: $\pm 3^\circ\text{C} \pm 1$ digit
- Thermocouples K, T, E, U, or N: -200 to -100°C:
 $\pm 2^\circ\text{C} \pm 1$ digit

- RTD input: $\pm 0.8^\circ\text{C} \pm 1$ digit or $\pm 0.2\% \pm 1$ digit of indicated value, whichever is larger
- mV input, voltage input, current input: $\pm 0.3\% \text{FS} \pm 1$ digit

Temperature effect on sensitivity:

$\pm 0.3\% \text{FS}/10^\circ\text{C}$

Indication resolution:

See Table 1

Input sampling rate:

50 ms

Input impedance:

- Thermocouple, mV input: 1 M Ω or more
- Current input: 150 Ω or less (built-in diode)
- Voltage input: About 1 M Ω

Variation by signal source resistance:

- Thermocouple, mV input: $\pm 0.3\% \text{FS} \pm 1$ digit per 100 Ω
- Voltage input: $\pm 0.3\% \text{FS} \pm 1$ digit per 500 Ω

Allowable wiring resistance:

RTD: 10 Ω or less (per wire)

Allowable input voltage:

- DC voltage input: within $\pm 35\text{V}$
- Current input: within ± 25 mA
- Thermocouple, RTD, mV input: within ± 5 V

Noise reduction ratio:

- Normal mode: 40 dB (50/60 Hz)
- Common mode: 120 dB (50/60 Hz)
- Between input and power supply: $\pm 1^\circ\text{C}$, at 220 V AC, 50/60 Hz

Input correction:

- User adjustment: $\pm 50\% \text{FS}$ for each of zero and span point
- Process value shift: $\pm 10\% \text{FS}$
- Input filter: 0.0 to 120.0 s
(filter OFF if set at 0.0)
- Square root extraction: -0.1 to 105% (OFF if set to -0.1%)

Overrange, underrange:

Beyond range of -5 to 105% (accuracy not guaranteed between -5 and 0, and between 100 and 105%FS)

*Pt (-200 to 850°C) input: out of the range between -2 to 105%

0 to 10 V DC input: out of the range between -2 to 105%
Thermocouple E input: out of the range between -5 to 102%

2.2 Remote SV input (optional)**Number of inputs:**

1

Input signal:

Voltage: 0 to 5 V DC /1 to 5 V DC/0 to 10 V DC,

Current: 0 to 20 mA DC/4 to 20 mA DC (a 250 Ω resistor is required for current input)

Input impedance:

About 1 M Ω

Sampling rate:

50 ms

2.3 Current transformer (CT) input (optional)**Input type:**

Single phase CT, 1 point

For 1 A to 30 A: CTL-6-S-H

For 20 A to 100 A: CTL-12-S36-8F

Range of detected current:

1 A to 100 A

Detected current accuracy:

Setpoint $\pm 5\% \text{FS}$

Detected current resolution:

0.1 A

ON time necessary for detection:

300 ms MIN.

2.4 Digital input (DI) (optional)**Number of points:**

Up to 3

Specifications:

No-voltage contact or transistor input

Contact capacity:

5 V DC, about 2 mA (per point)

Input judgment:

ON voltage: 2 V DC or lower

OFF voltage: 3 V DC or higher

Sampling pulse width:

50 ms MIN.

Functions:

Remote mode selection, SV changeover, control standby, AT startup, timer startup, alarm unlatch, program selection, start/stop/reset, PID switching (normal/reverse), etc.

2.5 Valve position feedback signal (potentiometer) input (optional)**Resistance range:**

100 Ω to 2.5 k Ω (three-wire)

Resolution:

0.5%FS

Input accuracy:

$\pm 1.0\% \text{FS}$

Temperature effect on sensitivity:

$\pm 0.5\% \text{FS}/10^\circ\text{C}$

Burnout function:

Not provided

3. Output section**3.1 Control output****Number of points:**

Up to 2 (2 points: Heating/cooling control)

Type:

selected among (1) to (6) below

(1) Relay contact output (SPST)

- Proportional cycle: 1 to 150 s

- Contact structure: SPST (single pole single throw)

- Contact capacity: 250 V AC/30 V DC, 3 A (resistive load)

- Minimum ON/OFF current: 10 mA (5 V DC)

- Mechanical life: 20 million operations MIN. (100 operations/min)

- Electrical life: 100,000 operations MIN. (rated load)

(2) Relay contact output (SPDT)

- Proportional cycle: 1 to 150 seconds

- Contact structure: SPDT (single pole double throw)

- Contact capacity: 250 V AC/30 V DC, 5 A (resistive load)

- Mechanical life: 50 million operations MIN. (100 operations/min)

- Electrical life: 100,000 operations MIN. (rated load)

(3) SSR drive output

- Proportional cycle: 1 to 150 s

- ON voltage: 12 V DC (between 10.7 and 13.2V DC)

- OFF voltage: 0.5 V DC or lower

- Maximum current: 20 mA DC
 - Load resistance: 600 Ω MIN.
- (4) Current output (0 to 20 mA DC/4 to 20 mA DC)
- Accuracy: ±5%FS
 - Load resistance: 500 Ω MAX.
- (5) Voltage output (0 to 5 V DC/1 to 5 V DC/0 to 10 V DC/2 to 10 V DC)
- Accuracy: ±5%FS
 - Load resistance: 10 kΩ MIN.
- (6) Motorized valve control output
- Contact structure: 2 SPST contacts without interlock circuit
 - *SPST: Single Pole Single Throw
 - Contact capacity: 250 V AC/30 V DC, 3A (resistive load)
 - Minimum ON/OFF current: 100 mA (24 V DC)
 - Mechanical life: 20 million operations MIN. (100 operations/min)
 - Electrical life: 100,000 operations MIN. (rated load)

3.2 Alarm output (optional)

Number of outputs:

Relay contact output: up to 5 (shared common)
up to 3 (independent common)

Output specifications:

Relay contact output
Contact structure: SPST (single pole single throw)
Contact capacity: 250 V AC/30 V DC, 1 A (resistive load)
Minimum ON/OFF current: 10 mA (5 V DC)
Mechanical life: 20 million operations MIN.
(100 operations/min)
Electrical life: 100,000 operations MIN. (rated load)

Output functions:

Alarm output (see “Alarm function”), main unit control mode output, program status output, control output 1 and 2, etc.

Output cycle:

100 ms

3.3 Re-transmission output (optional)

Number of points:

1

Type:

Current/voltage output (0 to 20 mA DC/4 to 20 mA DC/0 to 5 V DC/1 to 5 V DC/ 0 to 10 V DC/2 to 10 V DC)

- Guaranteed output range: 0 to 21 mA DC/0 to 10.5 V DC
- Accuracy: ±0.2%FS (±5%FS at 1 mA or smaller)
- Resolution: 10,000 MIN.
- Load resistance: 500 Ω MAX. (current), 10 kΩ MIN. (voltage)

Output cycle:

100 ms

Output contents:

PV, SV, DV, MV

Additional function:

Scaling function

4. Indication/setting section

4.1 Display unit

Type:

LCD (with backlight)

Indication contents:

Process value indication: 11-segment, 4-digit [white]
Setpoint indication: 11-segment, 4-digit [green]
Screen No. indication: 7-segment, 4-digit [orange]
Indication status: 42 indicator lamps

Luminance setting:

possible (4 steps)

4.2 Setting section

Type:

Sheet type keys (with emboss)

Number of keys:

5 keys

5. Control functions

5.1 Control types

ON/OFF control

PID control

- Dual control (heating/cooling)
- PID parameters determination: Auto tuning

Fuzzy PID control

- Dual control (heating/cooling)
- PID parameters determination: Auto tuning

Self tuning control

PID2 control

- Dual control (heating/cooling)
- PID parameters determination: Auto tuning

2-degrees-of-freedom PID

- PID parameters determination: Auto tuning

Position proportional PID (servo) control with position feedback

- Full stroke time: 30 seconds MIN.

5.2 Control parameters

- Proportional band (P): 0.1 to 999.9%
- Integral time (I): 0 to 3200 s
Integral time control invalidated when I = 0.
- Differential time (D): 0.0 to 999.9 s
Differential time control invalidated when D = 0.
- Control cycle: 100 to 900 ms (in 100 ms), 1 to 99 s (in seconds)
- Anti-reset windup:
0 to 100% of measurement range
- Hysteresis band: 50% of measurement range (at 2-position control only)
- Number of SV and PID combinations: 8 combinations.
Changed by any of parameter setting, digital input, communication, user function keying, zone change.

5.3 Control mode

Mode type:

Auto, Manual, Remote

* During 2-position control in Manual mode, 2-position manual operation with MV = 100% or 0% is operated.

Mode switching:

- Auto↔Manual: Balanceless·bumpless
- Auto/Manual → Remote: Balance·bumpless
- Auto/Manual ← Remote: Balance·bumpless

6. Alarm function

6.1 Number of alarm setting points

Up to 5 points (according to the number of DOs)

6.2 Alarm type

Process value (upper limit/lower limit, absolute/deviation, range), main unit error, etc.
(non-excitation, delay, latch, timer function option provided)

6.3 Heater current alarm function (optional)

*Current detector (CT) is to be prepared separately (see page 7.)

Detectable range:

1 A to 100 A

Detected current resolution:

0.1 A

Setting resolution:

0.1 A

Hysteresis:

0.0 A to 100.0 A

7. Communication function**7.1 RS-485 interface (optional)****Number of points:**

1 point

Physical specifications:

EIA-485

Protocol:

Modbus-RTU

Communication method:

Half duplex bit serial, Asynchronous communication

Code type:

Data length: 8 data bits. Parity: Odd, even, none.

Communication rate:

9600 bps, 19200 bps, 38.4 kbps, 115.2 kbps

Connection status:

Up to 32 units connectable including multidrop master function

Communication distance:

Up to 500 m (total connect extension)

Additional functions:

- Cooperative operation
The function in which several temperature controllers (as slave devices) can be operated by a master temperature controller.
- Programless communication
The function in which a temperature controller can communicate with a PLC without program.
Supported PLCs: Mitsubishi PLC Q series
Siemens PLC S7 series

8. Data backup at power failure

Memory protection: Protect by non-volatile memory

9. Self-diagnosis

Method: Program error supervision by watchdog timer

10. Operation and storage conditions**Operating ambient temperature:**

-10 to 50°C

Storage temperature:

-20 to 60°C

Operating/storage ambient humidity:

90%RH MAX. (no condensing)

Warm-up time:

30 min MIN

Vibration:During transportation 9.8 m/s² (1G) or less**Impact:**During transportation: 294 m/s² (30G) or less**11. Structure****Mounting method:**

Panel mount

External terminals:

Screw terminals, M3

Case: material:

- ABS, PPO
- Non-combustibility grade: UL94V-0 equivalent
- Color: Black

Protection structure:

- Panel front side: IP66, NEMA-4X equivalent
(When the panel is mounted using our genuine packing. Not water-proof if mounted closely together.)
- Body: IP20 equivalent (slits on top and bottom)
- Terminals: IP00 equivalent. Terminal cover can be mounted optionally.

Dimensions:

96 (W) × 96 (H) × 58 (D) mm

Weight:

approx. 220g

12. User customize function**12.1 Program (ramp/soak) function****Number of program steps:**

- 64 steps x 1 pattern,
- 32 steps x 2 pattern,
- 16 steps x 4 pattern
- 8 steps x 8 pattern
(1 step = 2 segments)

Control option:

Operation control by digital input
Status output by digital output

Basic functions:

- (1) Segment time can be set in "Hour, Minutes" or "Minutes, Seconds"
- (2) Guarantee soak
- (3) Repeat action
- (4) PV start
- (5) Delay start
- (6) Power restoring function

Memory backup:

EEPROM

12.2 User functions

Pressing the user key can perform Auto/Manual change, Standby ON/OFF change, local SV/remote SV change, ramp/soak change or other functions as assigned.

12.3 Password function

3-level password function

13. Simple power-monitoring function and operating days alarm**13.1 Simple power-monitoring function**

- By connecting a current transformer (to be prepared separately), electric power consumption of a heater can be displayed.
(Electric power is calculated with the fixed voltage value.)
- Current detector (CT) is to be prepared separately (see page 7.)
- Current detection range: 1 A to 100 A

13.2 Operating days alarm

- Displays the operating days and activates alarm output (optional) when it exceeds the setpoint.
- This function is useful for preventive maintenance because it let you know the appropriate time for maintenance work.

14. Certification

UL, C-UL

15. EU Directive Compliance

LVD (2014/35/EU)

EN 61010-1

EN 61010-2-030

EMC (2014/30/EU)

EN 61326-1 (Table 2)

EN 55011 (Group 1 Class A)

EN 61000-3-2 (Class A)

EN 61000-3-3

RoHS (2011/65/EU)

EN 50581

Table 1 Measurement range

Input type		Code (PvT)	Measurement range [°C]	Minimum input increment [°C]
RTD	Pt100	PT1	0.0 to 150.0	0.1
		PT2	0.0 to 300.0	0.1
		PT3	0.0 to 500.0	0.1
		PT4	0.0 to 600.0	0.1
		PT5	-50.0 to 100.0	0.1
		PT6	-100.0 to 200.0	0.1
		PT7	-199.9 to 600.0	0.1
		PT8	-200 to 850	1
Thermocouple	J	J1	0.0 to 400.0	0.1
		J2	-20.0 to 400.0	0.1
		J3	0.0 to 800.0	0.1
		J4	-100 to 1000	1
	K	K1	0 to 400	0.1
		K2	-20.0 to 500.0	0.1
		K3	0.0 to 800.0	0.1
		K4	-200 to 1300	1
	R	R	0 to 1700	1
	B	B	0 to 1800	1
	S	S	0 to 1700	1
	T	T1	-199.9 to 200.0	0.1
		T2	-199.9 to 400.0	0.1
	E	E1	0.0 to 800.0	0.1
		E2	-150.0 to 800.0	0.1
		E3	-200 to 800	1
	L	L	-100 to 850	1
	U	U1	-199.9 to 400.0	0.1
		U2	-200 to 400	1
	N	N	-200 to 1300	1
W	W	0 to 2300	1	
PL-II	PL-2	0 to 1300	1	
DC voltage	0 to 5 V	0-5V	-1999 to 9999 (Scaling range)	-
	1 to 5 V	1-5V		
	0 to 10 V	0-10		
	2 to 10 V	2-10		
	0 to 100 mV	MV		
DC current	0 to 20 mA	0-20		
	4 to 20 mA	4-20		

* Input signal, measurement range, and set value at the time of delivery are as follows:

Thermocouple K, Measurement range from 0 through 400°C, Set value 0°C.

Switching the input signal among thermocouple, RTD, current, and voltage is available by key operation on the front panel.

CODE SYMBOLS

<96 x 96 mm size>

Standard type

PXF 4 5 6 7 8 9 10 11 12 13
 9 A - 0 0

Digit	Specifications	Note	4	5	6	7	8	9	10	11	12	13
4	<Front panel size W × H> 96 × 96 mm		9									
5	—			A								
6	<Control output 1>											
	Relay contact (SPST)				A							
	Relay contact (SPDT)				B							
	SSR drive output				C							
	Current output				E							
	Voltage output				P							
7	<Control output 2>											
	None											
	Relay contact (SPST)					Y						
	SSR drive output					A						
	Current output					C						
	Voltage output					E						
	Re-transmission output (current)					P						
Re-transmission output (voltage)					R							
8	<Revision code>						S					
9	<Alarm output>						2					
	None								0			
	1 point								1			
	2 points								F			
	3 points								M			
	2 points (independent common)								J			
10	<Power supply voltage/instruction manual>											
	100 to 240 V AC, Japanese & English								Y			
	100 to 240 V AC, English								V			
	100 to 240 V AC, Chinese & English								W			
	24 V AC/DC, Japanese & English								A			
	24 V AC/DC, English								B			
	24 V AC/DC, Chinese & English								D			
11	<Option>											
	None									1		
	RS-485 Communication									M		
	Digital input (DI1, DI2)									T		
	Remote SV input + Digital input (DI3)	Note2								H		
	CT input + Digital input (DI1)	Note1								G		
	RS-485 communication + Digital input (DI1)									V		
RS-485 communication + Digital input (DI3, 4, 5) + Auxiliary alarm output (AL4, AL5)									C			
12	—										0	
13	—										0	0

Note 1: When using the CT input as a heater burnout alarm, add one alarm output for it in the 9th code.

Note 2: When using the current input for the remote SV input, add a 250-ohm resistor to the input terminal.

SCOPE OF DELIVERY

- Controller × 1
- Instruction manual × 1
- Panel mounting adapter × 2
- Watertight packing × 1

<96 x 96 mm size>

Motorized valve control type

Digit	Specifications	Note	4	5	6	7	8	9	10	11	12	13
4	<Front panel size W × H> 96 × 96 mm		PXF	9	A	Y	2	-				
5	-											
6	<Control output 1> Motorized valve control output (without PFB input) Motorized valve control output (with PFB input)											
7	<Control output 2> None											
8	<Revision code>											
9	<Alarm output> None 1 point 2 points 3 points 2 points (independent common)											
10	<Power supply voltage/instruction manual> 100 to 240 V AC, Japanese & English 100 to 240 V AC, English 100 to 240 V AC, Chinese & English 24 V AC/DC, Japanese & English 24 V AC/DC, English 24 V AC/DC, Chinese & English											
11	<Option> None RS-485 communication + Digital input (DI1, 2, 3)											
12	-											
13	-											

OPTIONAL ITEMS

Instruction manual for RS-485 communication function (MODBUS)	Type: INP-TN5A2227
Current detector (CT) 1 to 30 A	Type: ZOZ*CCTL-6-S-H
20 to 100 A	Type: ZOZ*CCTL-12-S36-8
Terminal cover	Type: ZZPPXF1-B100 (Note)
Parameter loader interface cable	Type: ZZP*TQ501923C3
Shunt resistor (250Ω ± 0.1%)	Type: ZZPPXR1-A190

Note) Two terminal covers are necessary.

Current detector (CT)

• Specification : 1 to 30 A

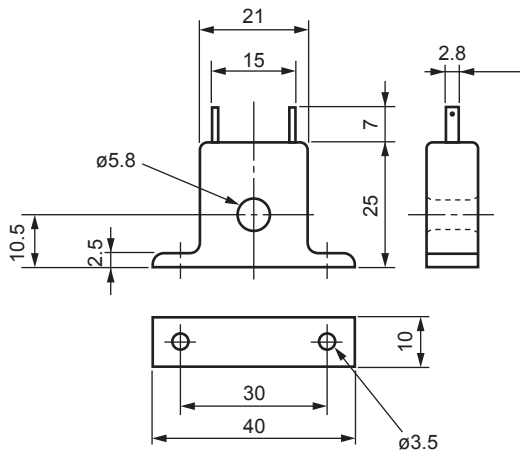

• Specification : 20 to 100 A

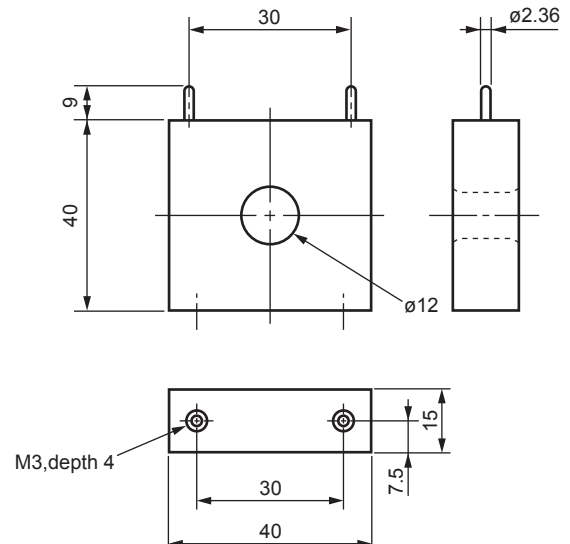

Note 1) Detection is available only for single phase heater.

Note 2) Unusable for heater control by thyristor phase angle control.

OUTLINE DIAGRAM (Unit : mm)

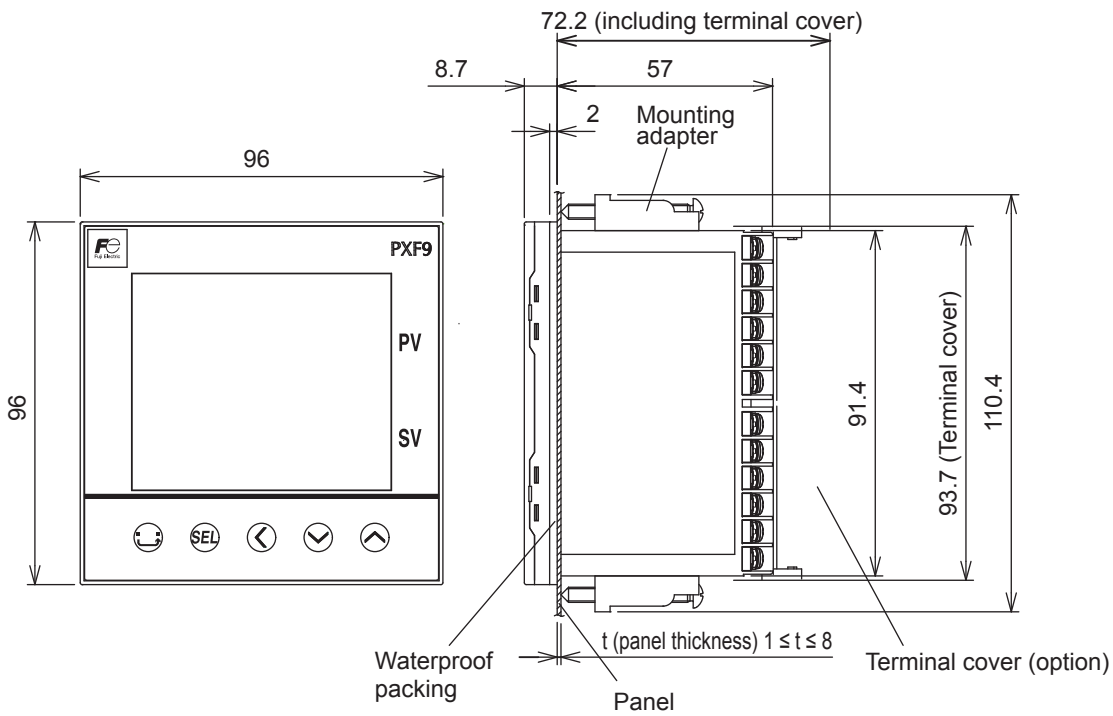

PANEL CUTOUT SIZE (Unit : mm)

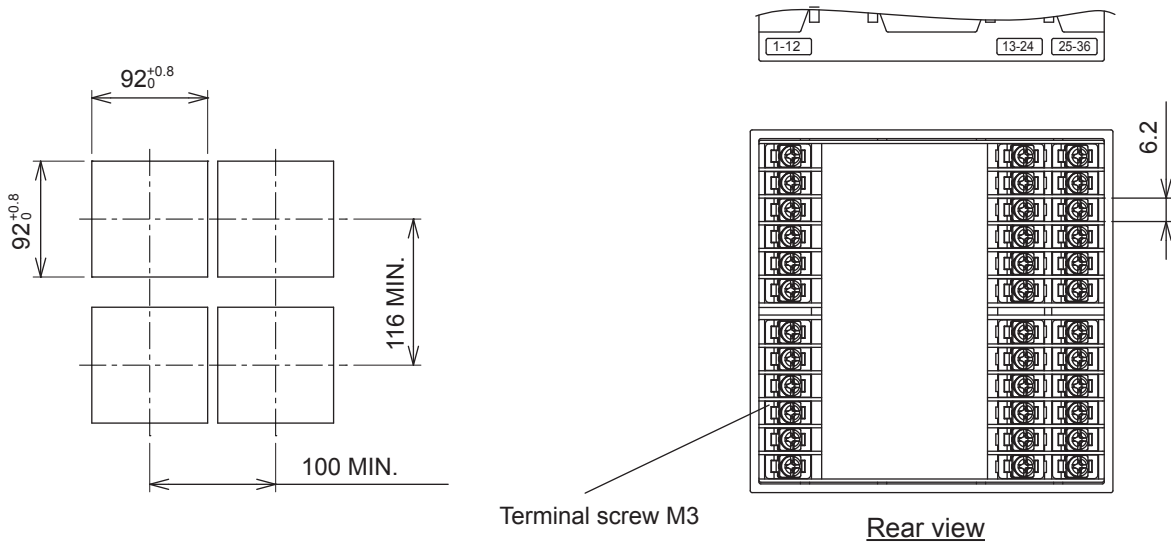

Terminal block is not attached to unused terminals (terminal 13 to 24) according to the model.

TERMINAL ALLOCATION

Standard type

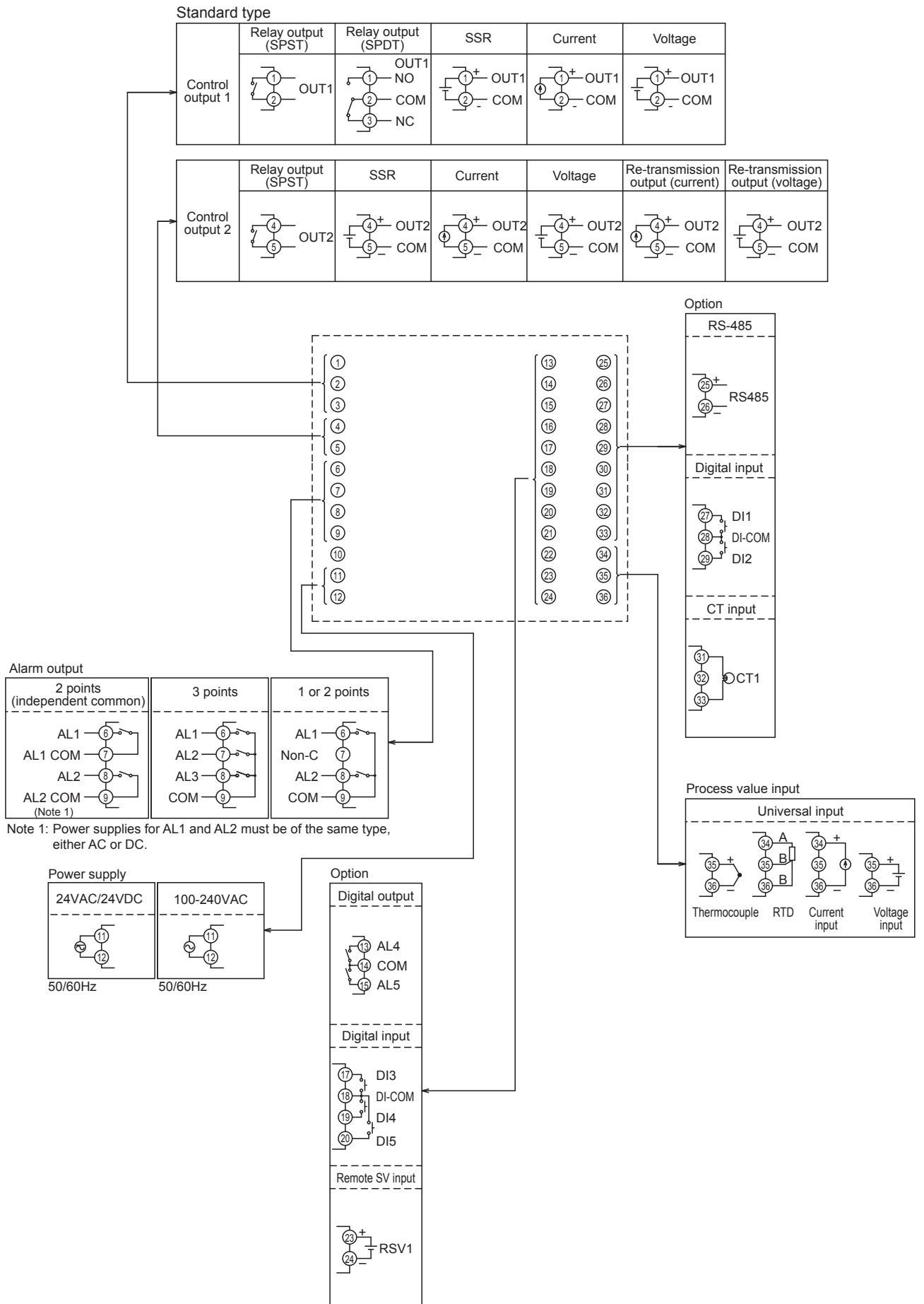

Motorized valve control type

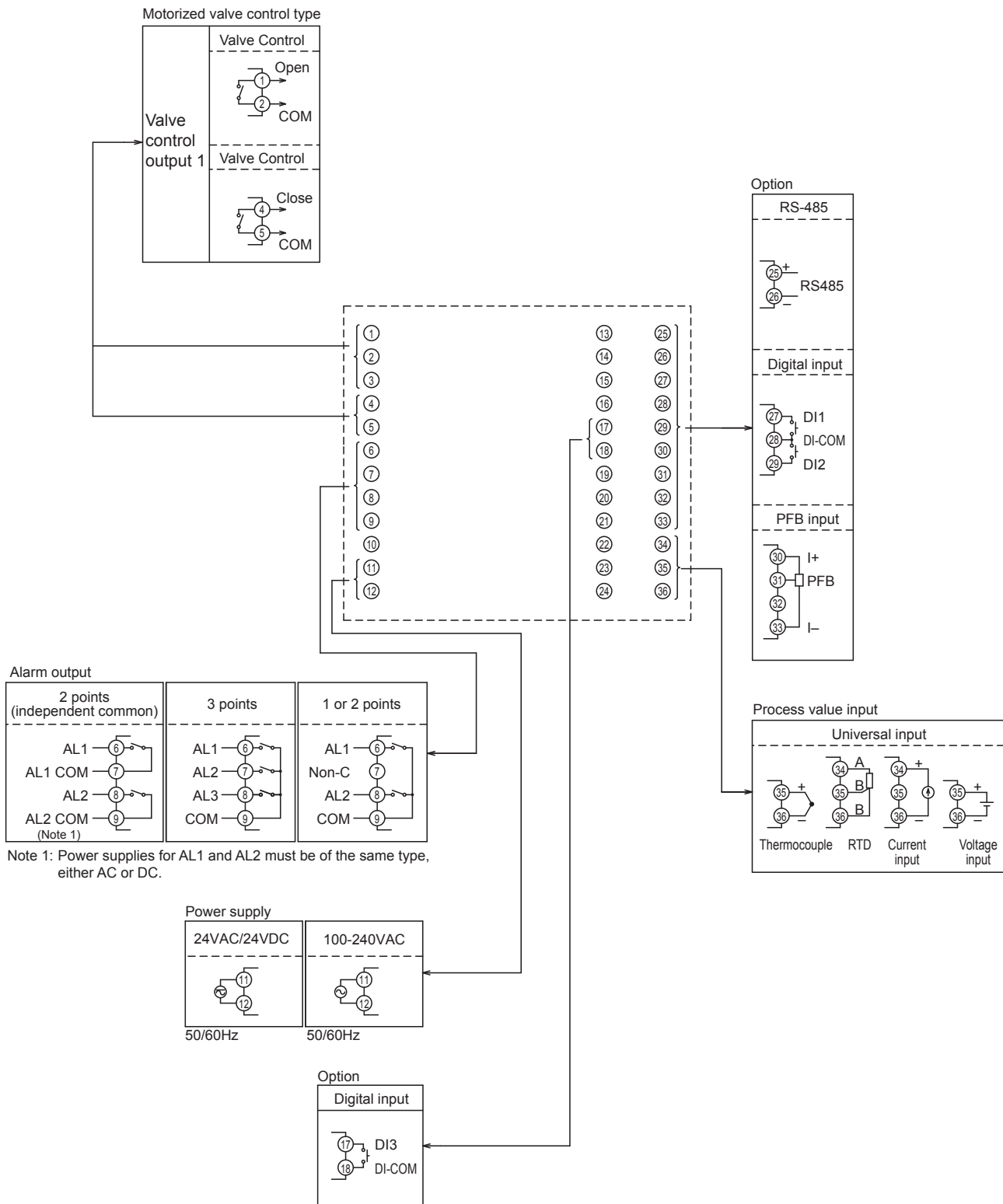

Note 1: Power supplies for AL1 and AL2 must be of the same type, either AC or DC.

INSULATION BLOCK DIAGRAM

Power		Internal circuit
Control output 1 (relay contact) or Motorized valve OPEN output		Process value input
Control output 2 (relay contact) or Motorized valve CLOSE output		Remote SV input
Alarm output 4 and 5 (relay contact)		CT input
Alarm output 1 (relay contact)	Alarm output 1 to 3 (relay contact)	Valve position feedback (PFB) input
Alarm output 2 (relay contact)		Control output 1 (SSR drive, current, voltage)
		Control output 2 (SSR drive, current, voltage) or Re-transmission output
		Digital input 1 to 3
		Communication (RS-485)

- When the 9th code is "J"
AL 1 and 2:
independent common
- When the 9th code is other than "J"
AL 1 to 3: shared common

_____ : Basic insulation
 _____ : Functional insulation
 - - - - - : No insulation

⚠ Caution on Safety

*Before using this product, be sure to read its instruction manual.

 Fuji Electric Co., Ltd.

Global Sales Section

Instrumentation & Sensors Planning Dept.

1, Fuji-machi, Hino-city, Tokyo 191-8502, Japan

<http://www.fujielectric.com>

Phone: +81-42-514-8930 Fax: +81-42-583-8275

<http://www.fujielectric.com/products/instruments/>