



WESCHLER INSTRUMENTS

DIVISION OF HUGHES CORPORATION

BarGraph Tricolor Series

Owners Manual

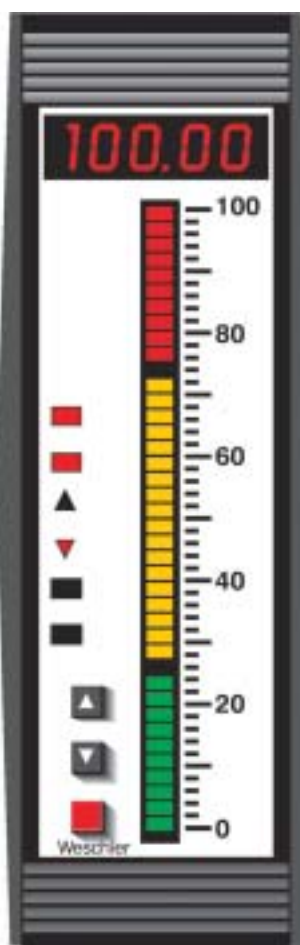

REVISION 3.3 08/04

Contents

1 INTRODUCTION	1
Scope	1
Features	1
Compatibility	1
How to Use this Manual	1
2 SETUP	2
Options	2
Normal Operation	2
Operation During Setup	3
Operator and Supervisor Setup	3
Activating Operator Setup	4
Operator Setup Actions	4
2.1 OPERATOR SETUP PROGRAMMING	4
Password	5
Alarm Setpoints	6
LED Brightness	7
Bar Flash Enable	7
Digital Flash Enable	8
Lamp Test	8
Run	8
2.2 SUPERVISOR SETUP PROGRAMMING	9
Activating Supervisor Setup	9
Supervisor Setup Functions	9
Supervisor Setup Command Summary	10
Password	11
Alarm Setpoints	12
Set Hysteresis	13
Set Alarm Delay	13
BarGraph™ Zero	14
BarGraph™ Full Scale	15
Set Bar Form	16
Set Bar Zero	17
Set Bar Full Scale	17
Enable/Disable Operator Setup	18
Enable/Disable Peak/Valley	18
Set Decimal Point	19
Set Bar Fill Mode	20
Set Bar Zone Colors	21
Set Hi Setpoint Color	23
Set Lo Setpoint Color	23
LED Brightness	24
Bar Flash Enable	24
Digital Flash Enable	25

Configure Retransmit Signal	25
Set Calibration Table	26
Set Analog Retransmit Zero Value	26
Set Analog Retransmit Fullscale Value	27
Set Specific Gravity Correction Factor	27
Lamp Test	28
Set Update Rate	28
Signal Source	29
Set Buffer Size	29
Set Communication ID	30
Exit Supervisor Setup	30
3 CALIBRATION	31
Calibration Methods	31
3.1 LINEAR CALIBRATION	32
Linear Calibration Procedure	32
3.2 NONLINEAR CALIBRATION	34
Nonlinear Calibration Commands	34
Nonlinear Calibration Procedure	35
4 PHYSICAL DIMENSIONS	37
4.1 BG252TC and BH252TC Physical Dimensions	37
4.2 BG241TC Physical Dimensions	37
4.3 BG261TC Physical Dimensions	38
4.4 BG251TC and BG281TC Physical Dimensions	38
4.5 Terminal Connections - BG-252TC and BH-252TC	39
4.6 Terminal Connections - BG-241TC, BG-251TC, BG-261TC and BG-281TC ...	40
5 Configuration Flowcharts	42
Operator Setup	42
Supervisor Setup	43
6 WARRANTY	46
7 SPECIFICATIONS	47

1 INTRODUCTION

Scope

This manual covers features and programming specifically for the following versions of Weschler Instruments BarGraph™ TC (TriColor) instruments:

- BG-252TC
- BV5ATC
- PC101TC
- BW1316TC
- BG-241TC
- BG-251TC
- BG-261TC
- BG-281TC

Note: Your BarGraph™ may not contain all the options described in this manual.

Features

Weschler Instruments BG TC, TriColor BarGraph provide the quickest way to spot problems in process control panels. Each segment in the LED Bar display can be illuminated as Red (danger), Yellow (caution) or Green (safe). TriColor BarGraph instruments also provide these features:

- 5 digit display with resolution to 0.01%
- Alphanumeric mnemonics for setup and calibration

Compatibility

Retrofit sizes for:

- GE/Yokogawa 180
- GE/Yokogawa AB40
- Crompton 128
- Dixson SA/BB 101
- Dixson BEW51
- Weschler VX252
- Sigma/International Instruments 1151
- Weston 1316
- ...and many others

How to Use this Manual

This manual provides details in these sections:

- Section 2 - Setup
- Section 3 - Calibration
- Section 4 - Mechanical dimensions, assemblies and terminal connections

2 SETUP

Options

Weschler BarGraph™ displays are individually configured for every purchase order. This manual is intended as a reference for *all* options that may be ordered on BarGraph™ displays. Your particular unit may not include all options listed in this manual.

Please consult the ordering guide and the part number on the BarGraph™ label for your applicable options.

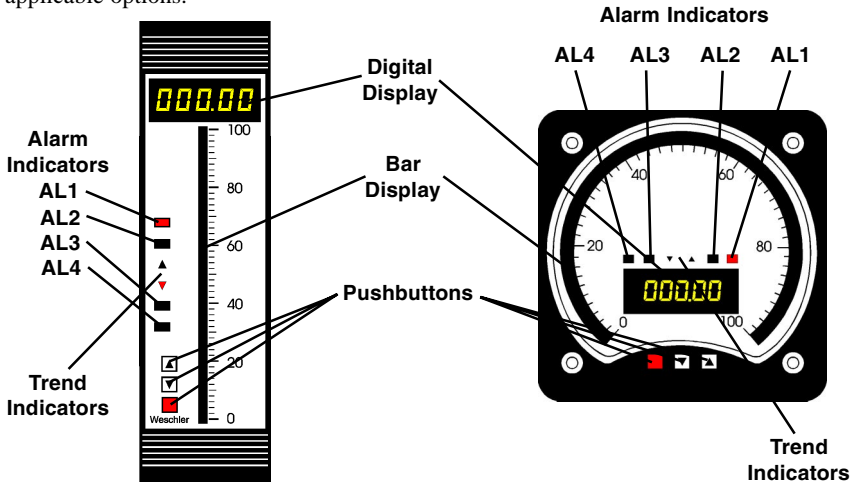

Normal Operation

The bar and digital display provide visual analog and digital indication of the process signal. If *bFLSH* and *dFLSH* are enabled, when the incoming signal is below the bottom end of the bar display, the first LED and digital display flash at a 1 Hz rate, indicating an underrange condition. When the process signal exceeds the full scale value, the top LED and digital display flash at a 1 Hz rate, indicating an overrange condition.

If the underrange or overrange condition exceeds the displayable range, the digital display will show *UndEr* or *OvEr*.

Three pushbutton switches are located on the front of the BarGraph™: two black pushbuttons with white triangular arrows and a red pushbutton with no markings. The pushbutton switch with the triangular arrow pointing up (▲) is the INCREASE pushbutton. The pushbutton with the triangular arrow pointing down (▼) is the DECREASE pushbutton. ENTER/SAVE is the red pushbutton (■).

During normal operation, the front panel pushbuttons may be used to display and reset Peak/Valley values or reset the relays if configured for latching. Pressing the INCREASE pushbutton (▲) will momentarily display the captured Peak value. The captured Peak value may be reset by pressing the INCREASE (▲) and ENTER/SAVE (■) pushbuttons simultaneously. Pressing the DECREASE pushbutton (▼) will momentarily display the captured Valley value. The captured Valley value may be reset by pressing the DECREASE (▼) and ENTER/SAVE (■) pushbuttons simultaneously. Latching relays may be reset by pressing the INCREASE (▲) and DECREASE (▼) pushbuttons simultaneously.

Pressing all three pushbuttons simultaneously will reset the captured Peak value, the captured Valley value and reset the latching relays.

Note that the state of latching relays and the Peak/Valley values are stored electronically. If power to the unit is interrupted the latched relay states will be lost and Peak/Valley values will be reset.

Operation During Setup

During setup programming the bar and digital display provide information to the user for programming. The digital display is used to show 3 to 5 character alphanumeric mnemonics for each of the setup functions and the bar display is used to provide an analog indication of functions and function values.

Information from the user is input through pushbuttons on the front panel.

Operator and Supervisor Setup

Setup functions are divided into two separate classes: Operator and Supervisor.

Operator Setup functions are those that may need to be changed on a routine basis for normal operation of the instrument. These functions include changing the alarm setpoint values, LED brightness control and Lamp Test. The ability to perform alarm setpoint programming, LED brightness control, Bar/Digital display flashing, Peak/Valley value reset and latching relay reset may all be disallowed by disabling Operator mode in Supervisor Setup.

Supervisor functions are those that should be setup only once when the instrument is installed and may cause damage to equipment or faulty operation if changed inadvertently. These functions include calibration settings, retransmit, ID settings, bar display modes and others.

Supervisor Setup functions may be programmed only after entry of a correct password. The password may be changed by the user in Supervisor Setup if the current password is known. The factory default password is 0. See notes under **PASS** function regarding changing the password.

The following pages have detailed descriptions of every function in Operator and Supervisor Setup. For quick reference, see Section 5, Configuration Flowcharts.

2.1 OPERATOR SETUP PROGRAMMING

Activating Operator Setup

If Operator Setup was enabled under Supervisor Setup, pressing the red ENTER/SAVE pushbutton and holding it for more than 3 seconds activates Operator Setup.

When operator setup is first enabled, **CONF** is displayed on the digital display. This is the point at which the user enters Operator Setup. **run** is the point at which the user exits Operator Setup.

Operator Setup Actions

Operator Setup allows the following functions.

Operator Setup functions are cycled through using the INCREASE and DECREASE pushbuttons. A particular function can be programmed by pressing the ENTER/SAVE pushbutton. Pressing the INCREASE pushbutton while **run** is displayed will go to **CONF** and pressing the DECREASE pushbutton while **CONF** is displayed will go to **run**.

CONF	■ Enter Operator Setup (Configure)
PASS	■ Enter password to access Supervisor Setup
AL1	■ * Adjust Alarm 1 setpoint
AL2	■ * Adjust Alarm 2 setpoint
AL3	■ * Adjust Alarm 3 setpoint
AL4	■ * Adjust Alarm 4 setpoint
brIGH	■ * Set LED brightness
b.FLSH	■ * Enable/Disable bar display flashing
d.FLSH	■ * Enable/Disable digital display flashing
LTEST	■ Lamp test
run	■ Leave Operator Setup (run)

Pressing ENTER/SAVE (■) pushbutton while any of the above are displayed will display the current setting and allow it to be modified. Each of the above functions is described on the following pages.

* Access to these functions under Operator Setup may be disabled through the **OPER** function under Supervisor Setup (see Section 2.2)

Note: If no pushbuttons are pressed for approximately 30 seconds, the unit will automatically return to run mode.

PASS

Password (Enter Supervisor Setup)

Supervisor Setup allows access to BarGraph parameters that should not be changed routinely and may even lead to dangerous situations if inadvertently changed. For this reason, entry into the Supervisor Setup mode is protected by a password.



The display will show 0 (zero), prompting the user to enter the correct password.

Press

ENTER/SAVE



INCREASE and DECREASE pushbuttons can be used to enter the password. Hold it until the value is reached. The longer the pushbutton is held, the faster the display moves to the required number.



Press

INCREASE

DECREASE

The password can be any numeric value between 19999 and 99999. It can only be set under Supervisor Setup mode. Entering the correct password under Operator Setup will allow entry into Supervisor Setup.



Press

ENTER/SAVE

Pressing the ENTER/SAVE pushbutton once the correct password number is displayed will allow entry to Supervisor Setup. If the correct password was not displayed, the display will continue on to the next available setting and will not enter Supervisor Setup.

Notes: As shipped from the factory, the password is set to 0. This allows the user to enter Supervisor Setup and change the password. It is recommended that the password be changed to something other than 0.

Remember your password! If you have trouble remembering the password, write it down. If there is no record of the password and access to Supervisor Setup is required, please contact the factory at (440) 238-2550.

AL1 AL2
AL3 AL4

Alarm Setpoints

Up to four alarm setpoints are provided, depending on the options ordered.

In Operator Setup these setpoint values may be examined and changed only if Operator Setup was enabled under Supervisor Setup (see Enable/Disable Operator Setup). The type of setpoint (*HI* or *LO*) and state of the relay contact (*Std* or *FSAFE*) may be examined but can only be changed in Supervisor Setup.



The display will show *HI* or *LO* to indicate whether the alarm was configured as a high setpoint or low setpoint in Supervisor Setup. *HI* indicates alarming when the signal is greater than the setpoint value. *LO* indicates alarming when the signal is less than the setpoint value. This cannot be changed in Operator Setup.

Press
ENTER/SAVE



Alarm relay state is displayed: either *Std* (standard) or *FSAFE* (failsafe). Standard outputs use a non-energized relay coil, i.e. the relay coil is energized to indicate an alarm condition. Failsafe outputs use an energized relay coil, i.e. the relay coil must be de-energized to indicate an alarm condition. This cannot be changed in Operator Setup.

Press
ENTER/SAVE



Setpoint value for this alarm is displayed. The bar and digital displays both indicate value of the setpoint.

Press
ENTER/SAVE



INCREASE and DECREASE pushbuttons can be used to change the setpoint value. Hold it until the new setpoint value is reached.

Press
INCREASE
DECREASE

The longer the pushbutton is held, the faster the display moves to the required setpoint value.



To save the new setpoint value, press the ENTER/SAVE pushbutton.

Press
ENTER/SAVE

Do not assume that the new value is saved once you have arrived at the new setpoint value and the BarGraph™ defaults to normal display mode. You must press ENTER/SAVE to store the new setpoint value and make it effective.

Notes: In Operator Setup mode, only the bar and digital displays are affected. All signal processing functions continue to operate at the current setup values. Thus, if you are using setpoint relays or retransmit capabilities, they continue to function as if the BarGraph™ was in the normal display mode.

br 19H

LED Brightness

LED brightness can be controlled from Operator Setup. Sixteen settings are available: *1* to *1b*. *1* is the dimmest setting while *1b* is the brightest. The factory default setting is *12*.



The display will show the current LED brightness setting.

Press
ENTER/SAVE



Pressing INCREASE or DECREASE will increment or decrement the LED brightness setting one step. The display brightness will change to show the effect of the new setting.

Press
INCREASE
DECREASE



To save the new LED brightness, press the ENTER/SAVE pushbutton.

Press
ENTER/SAVE

Do not assume that the new setting is saved once you have chosen it and the BarGraph™ defaults to normal display mode. You must press ENTER/SAVE to store the new LED brightness setting and make it effective.

b.FL5H

Bar Flash Enable

During an overrange/underrange condition, the Bar Display may be set to flash. This function is used to enable or disable the flashing of the Bar Display.



The display will show *ON* or *OFF* to indicate the current state.

Press
ENTER/SAVE



Pressing INCREASE sets flashing *ON*, pressing DECREASE sets flashing *OFF*.

Press
INCREASE
DECREASE



To save the new Bar Flash Enable setting, press the ENTER/SAVE pushbutton.

Press
ENTER/SAVE

Do not assume that the new setting is saved once you have chosen it and the BarGraph™ defaults to normal display mode. You must press ENTER/SAVE to store the new setting and make it effective.

d.FL5H

Digital Flash Enable

During an overrange/underrange condition, the Digital Display may be set to flash. This function is used to enable or disable the flashing of the Digital Display.



The display will show **ON** or **OFF** to indicate the current state.

Press
ENTER/SAVE



Pressing INCREASE sets flashing **ON**, pressing DECREASE sets flashing **OFF**.



Press
INCREASE
DECREASE



To save the new Digital Flash Enable setting, press the ENTER/SAVE pushbutton.

Press
ENTER/SAVE

Do not assume that the new setting is saved once you have chosen it and the BarGraph™ defaults to normal display mode. You must press ENTER/SAVE to store the new setting and make it effective.

L.E5E

Lamp Test



Press and hold ENTER/SAVE. All segments of the bar display be lit and the digital display will be lit as long as ENTER/SAVE is held.

Press
ENTER/SAVE

All segments of the bar display should be illuminated yellow and the digital display should show **8.8.8.8**. If any segment of the bar display is illuminated red or green, this indicates a failure. If any segment or decimal point of the digital display is not illuminated, this indicates a failure. Consult the factory for replacement.

rUn

Run

This is the point at which you exit Operator Setup.



The BarGraph will leave Operator Setup mode and resume normal operation.

Press
ENTER/SAVE

2.2 SUPERVISOR SETUP PROGRAMMING

Activating Supervisor Setup

Supervisor Setup can only be activated by entering the correct password (see page 5).

After the password is accepted, **RL I** is displayed on the digital display*. This is the point at which the user enters Supervisor Setup. To leave Supervisor Setup, scroll to **rUn** and press the ENTER/SAVE pushbutton or wait for time-out.

Supervisor Setup Functions

A summary of all Supervisor Setup functions is listed on the next page. Weschler BarGraph™ displays are custom built for every purchase order. Your particular unit may not include all functions listed on the next page depending on which options were ordered.

Supervisor Setup functions are cycled through using the INCREASE and DECREASE pushbuttons. A particular function can be set by pressing the ENTER/SAVE pushbutton. Pressing the INCREASE pushbutton while **rUn** is displayed will go to **LnF** and pressing the DECREASE pushbutton while **LnF** is displayed will go to **rUn**.



Next
Function



Previous
Function



Set
Function

* **RL I** will also be displayed if an incorrect password is entered, but the unit will remain in Operator Setup mode.

Note: If no pushbuttons are pressed for approximately 30 seconds, the unit will automatically return to run mode.

Supervisor Setup Command Summary

<i>ENF</i>	Entry (C onfiguration)	<i>b.COL</i>	Bar Zone Color
<i>PASS</i>	P assword	<i>H.I.COL</i>	High Setpoint Color
<i>AL1</i>	A larm 1	<i>LO.COL</i>	Low Setpoint Color
<i>AL2</i>	A larm 2	<i>brIGH</i>	LED B rightness
<i>AL3</i>	A larm 3	<i>b.FLSH</i>	Bar Flash Enable/Disable
<i>AL4</i>	A larm 4	<i>d.FLSH</i>	Digital Flash Enable/Disable
<i>HYS</i>	H ysteresis	<i>rEt</i>	R etransmit S ignal
<i>dELAY</i>	A larm D elay	<i>tABLE</i>	C alibration T able (nonlinear calibration)
<i>ZEro</i>	C alibrate Z ero	<i>A.ZEro</i>	A nalog R etransmit Z ero
<i>FULL</i>	C alibrate F ullscale	<i>A.FULL</i>	A nalog R etransmit F ullscale
<i>BAR</i>	B arform	<i>S.GRAU</i>	S pecific G ravty C orrection
<i>b.ZEro</i>	B ar Z ero	<i>L.tEST</i>	L amp T est
<i>b.FULL</i>	B ar F ullscale	<i>U.rATE</i>	U ppdate R ate
<i>OPER</i>	O perator Setup Enable/Disable	<i>SIGNAL</i>	S ignal S ource (analog/digital)
<i>PEAR</i>	P eak/Valley Enable/Disable	<i>b.SIZE</i>	B uffer S ize
<i>dEC</i>	D ecimal Point Position	<i>Id</i>	C ommunication I D
<i>b.FILL</i>	B ar Display F ill Mode	<i>rUn</i>	E xit Setup (r un)

Note: Depending on the options ordered, your BarGraph may not show all the functions listed above.

PASS

Password
(changing)

Supervisor Setup allows access to BarGraph parameters that should not be changed routinely and may even lead to dangerous situations if inadvertently changed. For this reason, entry into the Supervisor Setup mode is protected by a password. After entry into Supervisor Setup, you may change the password as follows:



The display will show the current password.

Press
ENTER/SAVE



INCREASE and DECREASE pushbuttons can be used to select a new password. Hold it until the new password value is reached. The longer the pushbutton is held, the faster the display moves.

Press
INCREASE
DECREASE

The password can be any numeric value between 19999 and 99999.



Press the ENTER/SAVE pushbutton to save the new password.

Press
ENTER/SAVE

Notes: As shipped from the factory, the password is set to 0. This allows the user to enter Supervisor Setup and change the password. It is recommended that the password be changed to something other than 0.

Remember your password! If you have trouble remembering the password, write it down. If there is no record of the password and access to Supervisor Setup is required, please contact the factory at (440) 238-2550.

AL1 AL2
AL3 AL4

Alarm Setpoints

Up to four alarm setpoints are provided, depending on the options ordered. Each of these setpoints may be programmed as a high or low setpoint and for standard or failsafe relay operation in Supervisor Setup.



The display will show **H I** or **L O** to indicate whether the alarm was configured as a high setpoint or low setpoint

Press
ENTER/SAVE



INCREASE or DECREASE pushbutton can now be used to set the alarm **H I** or **L O** respectively. **H I** indicates alarming when the signal is greater than the setpoint value. **L O** indicates alarming when the signal is less than the setpoint value.

Press
INCREASE
DECREASE



To save the new value, press the ENTER/SAVE pushbutton. Alarm output type is displayed: either **Std** (standard) or **FSAFE** (failsafe).

Press
ENTER/SAVE



INCREASE or DECREASE pushbutton can be used to change the alarm output type to standard or failsafe, respectively. Standard outputs use a non-energized relay coil, i.e. the relay coil is energized to indicate an alarm condition. Failsafe outputs use an energized relay coil, i.e. the relay coil must be de-energized to indicate an alarm condition.

Press
INCREASE
DECREASE



To save the new alarm output type, press the ENTER/SAVE pushbutton. The current alarm setpoint value will be displayed.

Press
ENTER/SAVE



INCREASE and DECREASE pushbuttons can be used to change the setpoint value. Hold it until the new setpoint value is reached.

Press
INCREASE
DECREASE

The longer the pushbutton is held, the faster the display moves to the required setpoint value.



To save the new setpoint value, press the ENTER/SAVE pushbutton.

Press
ENTER/SAVE

HYS

Set Hysteresis

Hysteresis may be set in 0.01% increments from 0 to 10% of Full Scale. Attempting to increment past 10% will **enable latching for all alarms**.



The display will show the current hysteresis setting.

Press
ENTER/SAVE



Pressing the INCREASE or DECREASE pushbutton will increase or decrease the hysteresis setting. Hold it until the desired value is reached. The longer the pushbutton is held, the faster the display moves to the required setting.

Press
INCREASE
DECREASE



Incrementing past 10% will enable latching on the alarms and display **LCH**.



Press ENTER/SAVE to store the new setting.

Press
ENTER/SAVE

Note: Relay latching is performed electronically. The latch state will be lost and reset if power is interrupted.

DELAY

Set Alarm Delay

The delay before alarms are activated may be set from 0 to 10000 milliseconds (0 to 10 seconds) in 100 millisecond (0.100 second) steps. This provides some filtering for momentary conditions that may exceed alarm values, but are not valid alarm conditions.

Note: This delay is in addition to the normal response time and Update Rate.



The display will show the current delay setting.

Press
ENTER/SAVE



INCREASE and DECREASE pushbuttons can be used to change the delay setting. Hold it until the new delay value is reached. Setting will show .000 to 10.000 seconds.

Press
INCREASE
DECREASE



The longer the pushbutton is held, the faster the display moves to the required value.



Press ENTER/SAVE to store the new setting.

Press
ENTER/SAVE

2E-0

BarGraph™ Zero

This is a calibration function. This function and BarGraph FullScale function are used to calibrate for linear process measurement. They affect the value displayed on the digital display of the BarGraph. For nonlinear process measurement, use the Table function. See Section 3, Calibration, for details.

There are two methods for linear calibration: *CAL* and *NOCAL*.

CAL requires the use of a calibrated laboratory standard to generate the desired 0 input for calibration. See Section 3, Calibration for a detailed Calibration Procedure using a laboratory standard.

NOCAL does not require a calibrated laboratory standard. Instead, the value of the input signal that corresponds to the zero point may be entered directly using the front panel pushbuttons and digital display. Note that this does not recalibrate the BarGraph: it merely defines what the number that corresponds to zero-scale input will be for the existing calibration.



The display will show the saved state, *CAL* or *NOCAL*.

Press
ENTER/SAVE



The display will toggle between *CAL* and *NOCAL*.

Press
INCREASE
DECREASE

CAL indicates that the user will use a laboratory standard to recalibrate the zero point (see Section 3 for the complete Calibration Procedure).

NOCAL indicates that the user will not use a laboratory standard, but will instead enter the input value corresponding to the zero point directly using the front panel pushbuttons and digital display.

The rest of this description applies only to *NOCAL*:



The display will show the current zero point input value.

Press
ENTER/SAVE



INCREASE and DECREASE pushbuttons can be used to change the zero point input value. Hold until the new zero point input value is reached.

Press
INCREASE
DECREASE

The longer the pushbutton is held, the faster the display moves to the required value.



Press ENTER/SAVE to store the new setting.

Press
ENTER/SAVE

FULL

BarGraph™ Full Scale

This is a calibration function. This function and BarGraph Zero function are used to calibrate for linear process measurement. They affect the value displayed on the digital display of the BarGraph. For nonlinear process measurement, use the Table function. See Section 3, Calibration, for details.

There are two methods for linear calibration: *CAL* and *NOCAL*.

CAL requires the use of a calibrated laboratory standard to generate the desired fullscale input for calibration. See Section 3, Calibration, for a detailed Calibration Procedure using a laboratory standard.

NOCAL does not require a calibrated laboratory standard. Instead, the value of the input signal that corresponds to the fullscale point may be entered directly using the front panel pushbuttons and digital display. Note that this does not recalibrate the BarGraph: it merely defines what the number that corresponds to fullscale input will be for the existing calibration.



The display will show the saved state, *CAL* or *NOCAL*.

Press
ENTER/SAVE



The display will toggle between *CAL* and *NOCAL*.



Press
INCREASE
DECREASE

CAL indicates that the user will use a laboratory standard to recalibrate the fullscale point (see Section 3 for the complete Calibration Procedure).

NOCAL indicates that the user will not use a laboratory standard, but will instead enter the input value corresponding to the fullscale point directly using the front panel pushbuttons and digital display.

The rest of this description applies only to *NOCAL*:



The display will show the current fullscale point input value.

Press
ENTER/SAVE



INCREASE and DECREASE pushbuttons can be used to change the zero point input value. Hold until the new fullscale point input value is reached.



Press
INCREASE
DECREASE

The longer the pushbutton is held, the faster the display moves to the required value.



Press ENTER/SAVE to store the new setting.

Press
ENTER/SAVE

bAr

Set Bar Form

This function allows the user to set the bar display format. The most common display format is bottom zero, i.e.; starts at the bottom (or most left for horizontal displays) and increasing up (towards the right for horizontal displays). The BarGraph™ zero point can be located or referenced anywhere on or off the scale in this setup.



The display will show the current barform. Options for barform and the order they appear in are shown below.

Press
ENTER/SAVE



Pressing the INCREASE or DECREASE pushbutton will cycle through the barform options shown below.

Press
INCREASE
DECREASE



Bottom 0 - BarGraph™ reads 0% of Full Scale at the bottom and increasing up to 100% of Full Scale at the top.

Center 0 - Zero point at 50% of bar display. BarGraph™ reads -50% of Full Scale at the bottom and increases up to +50% at the top.

Top 0 - Zero point at 100% of bar display. This effectively reverses the bar display, with -100% of Full Scale at the bottom of bar display and 0% of Full Scale at the top.

Variable - allows the user to set any arbitrary values for the bottom and top of bar display (see Set Bar Zero and Set Bar Full Scale).

Deviation - allows the user to set any arbitrary values for the bottom and top of bar display (see Set Bar Zero and Set Bar Full Scale). The center of the bar display is set at $\frac{1}{2}(bZERO + bFULL)$ and shows + or - variations around the center point.



Press ENTER/SAVE to store the new setting.

Press
ENTER/SAVE

b.ZE-0

Set Bar Zero

This function will not be enabled or displayed unless barform has been set to **Deviation** or **Variable barform** (see **Barform function**). The BarGraph™ zero display point may be set to a certain display value. This is not a calibration function. It only affects the range of values that the bar display will show. This function can be used to limit the lowest value that the BarGraph™ will display. See Example at bottom of page.



The display will show the current BarGraph™ zero display point.

Press

ENTER/SAVE



Pressing the INCREASE or DECREASE pushbutton will increase or decrease the zero display point.

Press

INCREASE

DECREASE



Press ENTER/SAVE to store the new setting.

Press

ENTER/SAVE

b.FULL

Set Bar Full Scale

This function will not be enabled or displayed unless barform has been set to **Deviation** or **Variable barform** (see **Barform function**). The BarGraph™ Full Scale display point may be set to a display value. This is not a calibration command. It only affects the bar display. This command and the Set Bar Zero function may be used to limit the values shown on the bar display to a specific region of interest. See Example at bottom of page.



The display will show the current BarGraph™ Full Scale display value.

Press

ENTER/SAVE



Pressing the INCREASE or DECREASE pushbutton will increase or decrease the Full Scale display value.

Press

INCREASE

DECREASE



Press ENTER/SAVE to store the new setting.

Press

ENTER/SAVE

Example: If the BarGraph is monitoring a process that runs from 0 to 120, but the process never falls below 110 or rises above 115, displaying from 0 to 120 on the bar display will force the operating region to the last 1/12 of the bar display. Setting **b.ZE-0** to 110 and **b.FULL** to 115 will force the entire bar to display only the region of interest.

OPER

Enable/Disable Operator Setup

Operator Setup can be enabled or disabled through this function (see page 4). If Operator Setup is disabled, only LampTest is available.



The display will show **OFF** or **ON** to indicate whether Operator Setup is currently disabled or enabled.

Press
ENTER/SAVE



Pressing the INCREASE or DECREASE pushbutton will set Operator Setup **ON** or **OFF** respectively.

Press
INCREASE
DECREASE



Press ENTER/SAVE to store the new setting.

Press
ENTER/SAVE

PEA

Enable/Disable Peak/Valley

Peak/Valley allows the BarGraph™ to display the highest (Peak) and lowest (Valley) level during the reading cycle, as determined by the reset. During normal operation, the front panel pushbuttons may be used to display and reset Peak/Valley values. Pressing the INCREASE pushbutton (▲) will momentarily display the captured Peak value. The captured Peak value may be reset by pressing the INCREASE (▲) and ENTER/SAVE (■) pushbuttons simultaneously. Pressing the DECREASE pushbutton (▼) will momentarily display the captured Valley value. The captured Valley value may be reset by pressing the DECREASE (▼) and ENTER/SAVE (■) pushbuttons simultaneously. If Operator Setup is disabled, the Peak/Valley values may still be examined, but they cannot be cleared.



The display will show **OFF** or **ON** to indicate the current state of Peak/Valley function.

Press
ENTER/SAVE



Pressing the INCREASE or DECREASE pushbutton will set Peak/Valley **ON** or **OFF** respectively.

Press
INCREASE
DECREASE



Press ENTER/SAVE to store the new setting.

Press
ENTER/SAVE

d E C

Set Decimal Point

This function is used to set the position of the decimal point on the digital display.



The display will show the current display decimal point setting. Options for display decimal settings and the order they appear are shown below.

Press
ENTER/SAVE



Pressing the INCREASE or DECREASE pushbutton will cycle through the decimal options shown below.

Press
INCREASE
DECREASE

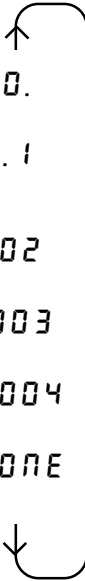

0 digits after the decimal point.

1 digit after the decimal point.

2 digits after the decimal point.

3 digits after the decimal point.

4 digits after the decimal point.

No decimal point.



Press ENTER/SAVE to store the new setting.

Press
ENTER/SAVE

b.F ILL

Set Bar Fill Mode

This function is used to control how the bar display changes color. The **b.CDL** function is used to set the colors.

Five different regions in the bar display are defined by **RL 1** through **RL 4**:

- $> RL 1$
- $RL 1$ to $RL 2$
- $RL 2$ to $RL 3$
- $RL 3$ to $RL 4$
- $< RL 4$

Note: These regions assume that **RL 1** is the highest and **RL 4** the lowest alarm setpoints. Setpoints may be arranged in any order, however.

The color of the bar in each of these regions may be defined by the **b.CDL** function.



The display will show the current Bar Fill setting. Options for this setting and the order they appear are shown below.

Press
ENTER/SAVE



Pressing the INCREASE or DECREASE pushbutton will cycle through the options shown below.

Press
INCREASE
DECREASE



TriColor mode. The bar is one solid color that changes for each of the regions described above. Typically, the bar is set for **green** (safe) for **RL 2** to **RL 3**, **yellow** (caution) for **RL 1** to **RL 2** or **RL 3** to **RL 4** and **red** (danger) for $> RL 1$ or $< RL 4$.

Color banding mode. The bar has a specific color in each of 5 different regions on the display. Typically, the bar is set for **green** (safe) for **RL 2** to **RL 3**, **yellow** (caution) for **RL 1** to **RL 2** or **RL 3** to **RL 4** and **red** (danger) for $> RL 1$ or $< RL 4$.

Note: When in Variation or Deviation mode (see Barform), 6 regions may be present due to the Zero point.



Press ENTER/SAVE to store the new setting.

Press
ENTER/SAVE

b.c.o.l

Set Bar Zone Colors

This function is used to set the color of the bar display in 5 distinct regions on the bar display.

Five different regions in the bar display are defined by *RL 1* through *RL 4*:

- $> RL 1$
- $RL 1$ to $RL 2$
- $RL 2$ to $RL 3$
- $RL 3$ to $RL 4$
- $< RL 4$

Note: These regions assume that *RL 1* is the highest and *RL 4* the lowest alarm setpoints. Setpoints may be arranged in any order, however, and will be displayed highest to lowest.

The color of the bar in each of these regions may be defined by actions shown below:



The display will show the current maximum scale setting. The bar shows the color displayed while the bar is in the region $> RL 1$.

Press
ENTER/SAVE



Pressing the INCREASE or DECREASE pushbutton will cycle through the colors Yellow, Green and Red. The bar display color will change to show the current choice.

Press
INCREASE
DECREASE

Typically, this is set to **Red** (danger).



The display will show the current *RL 1* setpoint value. The bar shows the color displayed while the bar is in the region $RL 1$ to $RL 2$.

Press
ENTER/SAVE



Pressing the INCREASE or DECREASE pushbutton will cycle through the colors Yellow, Green and Red. The bar display color will change to show the current choice.

Press
INCREASE
DECREASE

Typically, this is set to **Yellow** (caution).



The display will show the current *RL 2* setpoint value. The bar shows the color displayed while the bar is in the region $RL 2$ to $RL 3$.

Press
ENTER/SAVE



Pressing the INCREASE or DECREASE pushbutton will cycle through the colors Yellow, Green and Red. The bar display color will change to show the current choice.

Press
INCREASE
DECREASE

Typically, this is set to **Green** (safe).



Press
ENTER/SAVE

The display will show the current $RL\ 3$ setpoint value. The bar shows the color displayed while the bar is in the region $RL\ 3$ to $RL\ 4$.



Press
INCREASE
DECREASE



Pressing the INCREASE or DECREASE pushbutton will cycle through the colors Yellow, Green and Red. The bar display color will change to show the current choice.

Typically, this is set to **Yellow** (caution).



Press
ENTER/SAVE

The display will show the current $RL\ 4$ setpoint value. The bar shows the color displayed while the bar is in the region $< RL\ 4$.



Press
INCREASE
DECREASE



Pressing the INCREASE or DECREASE pushbutton will cycle through the colors Yellow, Green and Red. The bar display color will change to show the current choice.

Typically, this is set to **Red** (danger).



Press
ENTER/SAVE

The new settings will be saved.

Notes: When in Variation or Deviation mode (see Barform), 6 regions may be present due to the Zero point.

If new alarm setpoints were just entered, you must go to run mode before they will show up here.

Example: If $b.F\ iLL$ is set to $tr\ i$ (TriColor mode) and the typical colors described above are chosen, the bar display will be Green as long as the display value is between the $RL\ 2$ and $RL\ 3$ setpoints. The entire bar will illuminate Yellow in the regions $RL\ 1$ to $RL\ 2$ or $RL\ 3$ to $RL\ 4$. The entire bar will illuminate Red in the regions $> RL\ 1$ or $< RL\ 4$.

Example: If $b.F\ iLL$ is set to $band$ (Banding mode) and the typical colors described above are chosen, when the $RL\ 1$ alarm setpoint is exceeded, the bar will be three colors: Yellow between the $RL\ 1$ and $RL\ 2$ setpoints, Green between the $RL\ 2$ and $RL\ 3$ setpoints, Red $< RL\ 4$ and Red $> RL\ 1$.

H I.COL

Set Hi Setpoint Color

This function is active only if **bF iLL** was set to **Er i (TriColor)**. This function is used to set the default color for the **Hi** setpoints. One segment of the bar display will be illuminated in this color at the alarm setpoint values.



The display will show the current **Hi** setpoint color setting.

Press
ENTER/SAVE



Pressing INCREASE or DECREASE will increment or decrement the LED brightness setting one step. The display will change to show the effect of the new setting.

Press
INCREASE
DECREASE



To save the new **Hi** setpoint color setting, press the ENTER/SAVE pushbutton.

Press
ENTER/SAVE

Note: The **Hi** setpoint color will always differ from the bar color and **Lo** setpoint color.

LO.COL

Set Lo Setpoint Color

This function is active only if **bF iLL** was set to **Er i (TriColor)**. This function is used to set the default color for the **Lo** setpoints. One segment of the bar display will be illuminated in this color at the alarm setpoint values.



The bar display will change to a solid bar with the current **Lo** setpoint color setting.

Press
ENTER/SAVE



Pressing the INCREASE or DECREASE pushbutton will cycle through the colors Yellow, Green and Red. The bar display color will change to show the current choice.

Press
INCREASE
DECREASE



Press ENTER/SAVE to store the new setting.

Press
ENTER/SAVE

Note: The **Lo** setpoint color will always differ from the bar color and **Hi** setpoint color.

br 19H

LED Brightness

This function controls LED brightness. Sixteen settings are available: *1* to *1b*. *1* is the dimmest setting while *1b* is the brightest. The factory default setting is *12*.



The display will show the current LED brightness setting.

Press
ENTER/SAVE



Pressing INCREASE or DECREASE will increment or decrement the LED brightness setting one step. The display brightness will change to show the effect of the new setting.

Press
INCREASE
DECREASE



To save the new LED brightness, press the ENTER/SAVE pushbutton.

Press
ENTER/SAVE

b.FL5H

Bar Flash Enable

During an overrange/underrange condition, the Bar Display may be set to flash. This function is used to enable or disable the flashing of the Bar Display.



The display will show *0n* or *0FF* to indicate the current state.

Press
ENTER/SAVE



Pressing INCREASE sets flashing *0n*, pressing DECREASE sets flashing *0FF*.

Press
INCREASE
DECREASE



To save the new Bar Flash Enable setting, press the ENTER/SAVE pushbutton.

Press
ENTER/SAVE

d.FL5H

Digital Flash Enable

During an overrange/underrange condition, the Digital Display may be set to flash. This function is used to enable or disable the flashing of the Digital Display.



The display will show *ON* or *OFF* to indicate the current state.

Press
ENTER/SAVE



Pressing INCREASE sets flashing *ON*, pressing DECREASE sets flashing *OFF*.



Press
INCREASE
DECREASE



To save the new Digital Flash Enable setting, press the ENTER/SAVE pushbutton.

Press
ENTER/SAVE

rEt

Configure Retransmit Signal

This function controls the source of the retransmit signal. The retransmit signal may be configured to track the digital display or the bar display.



The display will show *digit* or *bar* to indicate the current state.

Press
ENTER/SAVE



Pressing INCREASE or DECREASE will set the retransmit signal to *digit* or *bar* respectively. If it is set to *digit*, the retransmit signal will track the digital display. If set to *bar*, it will track the bar display.



Press
INCREASE
DECREASE



To save the new retransmit signal setting, press the ENTER/SAVE pushbutton.

Press
ENTER/SAVE

TABLE

Set Calibration Table

This is a calibration function. Use a calibration table instead of Zero and FullScale settings when nonlinear process variables are monitored.

This function will not be displayed or active unless two jumpers are installed on JA1, a jumper block on the BarGraph printed circuit board. These are set at the factory, when required.

Unlike the Zero and FullScale calibration settings, there is not a *NOCAL* subfunction. You *must* use a calibrated laboratory standard to supply input values and follow the calibration procedure described in Section 3 to calibrate the BarGraph.

Please see the Calibration section (Section 3) for details on the two methods of calibration and details on using the calibration commands.

A.2E-0

Set Analog Retransmit Zero Value

This function controls the zero value of the analog retransmit signal. It may be set to any value between 0 and 20 mA (milliAmps) in 0.001 mA increments. Typical values are 0 for a 0 to 1 mA signal and 4 mA for a 4 to 20 mA signal.



The display will show the current retransmit zero value in mA.

Press
ENTER/SAVE



Pressing the INCREASE or DECREASE pushbutton will increase or decrease the retransmit setting. Hold it until the desired value is reached. The longer the pushbutton is held, the faster the display moves to the required setting.

Press
INCREASE
DECREASE



To save the new retransmit zero setting, press the ENTER/SAVE pushbutton.

Press
ENTER/SAVE

A.FULL

Set Analog Retransmit Fullscale Value

This function controls the fullscale value of the analog retransmit signal. It may be set to any value between 0 and 20 mA (milliAmps) in 0.001 mA increments. Typical values are 1 for a 0 to 1 mA signal and 20 mA for a 4 to 20 mA signal.



The display will show the current retransmit fullscale value.

Press
ENTER/SAVE



Pressing the INCREASE or DECREASE pushbutton will increase or decrease the retransmit setting. Hold it until the desired value is reached. The longer the pushbutton is held, the faster the display moves to the required setting.



Press
INCREASE
DECREASE



To save the new retransmit fullscale setting, press the ENTER/SAVE pushbutton.

Press
ENTER/SAVE

5.9rAu

Set Specific Gravity Correction Factor

This function allows the entry of a correction factor for specific gravity. The correction factor may be set from 0 to 2.000 in increments of .001.

This correction factor is a simple multiplier. Any input values are multiplied by this factor before being displayed.



The display will show the current specific gravity correction factor setting.

Press
ENTER/SAVE



Pressing the INCREASE or DECREASE pushbutton will increase or decrease the specific gravity correction factor setting. The correction factor may be set from 0 to 2.000 in increments of .001.



Press
INCREASE
DECREASE



Press ENTER/SAVE to store the new setting.

Press
ENTER/SAVE

L.T.E.S.T

Lamp Test



Press and hold ENTER/SAVE. All segments of the bar display be lit and the digital display will be lit as long as ENTER/SAVE is held.

Press

ENTER/SAVE

All segments of the bar display should be illuminated yellow and the digital display should show **8.8.8.8.8**. If any segment of the bar display is illuminated red or green, this indicates a failure. If any segment or decimal point of the digital display is not illuminated, this indicates a failure. Consult the factory for replacement.

U.R.A.T.E

Set Update Rate

This function is used to set BarGraph™ Update Rate for display of new values. It may be set from 0.000 to 10.000 seconds in 0.1 second increments.

When set to 0.000, the BarGraph™ still needs some time to take a new reading and display it. This time is nominally 0.3 seconds. The Update Rate specifies an additional time that may be added to this time to further slow updated readings to the bar and digital displays.



The display will show the current Update Rate.

Press

ENTER/SAVE



Pressing the INCREASE or DECREASE pushbutton will increase or decrease the Update Rate in 0.1 second increments.

Press

INCREASE

DECREASE



Press ENTER/SAVE to store the new setting.

Press

ENTER/SAVE

SIGNAL

Signal Source

This function defines which signal source will be displayed. There are two choices:

- *dC-AC* - the signal source is an AC or DC signal input (analog)
- *ASCII* - the display value is sent as ASCII characters from a serial port (digital)



The display will show the current signal source.

Press
ENTER/SAVE



Pressing the INCREASE or DECREASE pushbutton will set the signal source to *dC-AC* or *ASCII* respectively.

Press
INCREASE
DECREASE



To save the new signal source setting, press the ENTER/SAVE pushbutton.

Press
ENTER/SAVE

6.5 12E

Set Buffer Size

This function sets the number of readings averaged before the display is updated. The number of readings is the size of the buffer.



The display will show the current buffer size.

Press
ENTER/SAVE



Pressing the INCREASE or DECREASE pushbutton will increase or decrease the buffer size. The minimum is 1; the maximum is 20.

Press
INCREASE
DECREASE



Press ENTER/SAVE to store the new setting.

Press
ENTER/SAVE

id

Set Communication ID

This function is used to set BarGraph™ communication ID. Each BarGraph™ hooked to the communication lines must have its own unique ID to distinguish it from other units. Communication ID's may range from 00 to 99.



The display will show the current communication ID.

Press
ENTER/SAVE



Pressing the INCREASE or DECREASE pushbutton will increase or decrease the communication ID.

Press
INCREASE
DECREASE



Press ENTER/SAVE to store the new setting.

Press
ENTER/SAVE

r u n

Exit Supervisor Setup

This is the point at which Supervisor Setup must be exited.



The BarGraph will exit Supervisor Setup mode and resume normal operation.

Press
ENTER/SAVE

3 CALIBRATION

Calibration Methods

The first step in the calibration process is to decide which calibration method will be used. There are two different calibration methods available. Choice of calibration method depends on the process being monitored.

The first method involves a simple two-point calibration and is useful for linear process variables. Two points are calibrated: one at Zero and one at Full Scale. The process variable is assumed to be linear (straight line) between these two points.

The second method involves calibration at a number of points and performs linear interpolation between these points. This method of calibration is useful for nonlinear process variables. As few as three or as many as 50 points may be entered and calibrated.

The two different methods of calibration are illustrated graphically below:

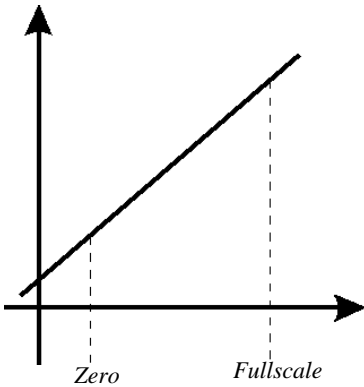

Linear Calibration

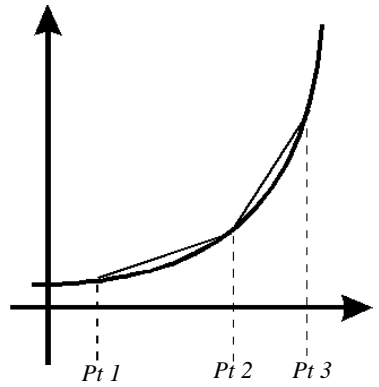

Nonlinear Calibration

Non-linear calibration, using the **TABLE** function, must be activated at the factory. Adjustment of the calibration points is described in Section 3.2.

3.1 LINEAR CALIBRATION



WARNING: PREVENT DAMAGE TO YOUR BARGRAPH™!

The BarGraph™ was configured at the factory for certain Zero and Full Scale values. These values should not vary more than 20% or damage may occur during severe overrange conditions. Identify the Zero and Full Scale values from the INPUT data on the BarGraph™ label. If you need significant changes to your configuration, the input circuitry might require modification. Consult the factory for assistance.

Linear Calibration Procedure

1. To calibrate the BG252TC or BH252TC, access to Supervisor Setup functions is required. To do this, the *PASS* function must be accessed and the correct password entered as described on page 5 of this manual.
2. To change the BarGraph Zero, press the INCREASE (▲) or DECREASE (▼) pushbuttons until the *ZERO* display appears on the digital display. Press ENTER (■).
3. There are two options under the *ZERO* menu: *CAL* and *NOCAL*. To calibrate BarGraph Zero, *CAL* must be displayed and the ENTER (■) pushbutton pressed. Pressing the INCREASE (▲) or DECREASE (▼) pushbuttons will toggle between *CAL* and *NOCAL*. Make sure that *CAL* appears on the digital display and press ENTER (■).
4. The display will change to show *000* (or previously set BarGraph Zero) on the digital display.
5. **Apply the desired zero input value into the BarGraph signal input terminals.** Use a calibrated lab-standard.
6. Press INCREASE (▲) or DECREASE (▼) to load the new Zero value into the meter.
7. Make sure the desired bar segment and digital display value are correct. Press the red ENTER push button and hold it. The desired Zero value is stored in memory and the display changes from the Zero value to *FULL* indicating that the BarGraph is ready to calibrate the full-scale value next.
8. There are two options under the *FULL* function: *CAL* and *NOCAL*. To calibrate BarGraph fullscale, *CAL* must be displayed and the ENTER (■) pushbutton pressed. Pressing the INCREASE (▲) or DECREASE (▼) pushbuttons will toggle between *CAL* and *NOCAL*. Make sure that *CAL* appears on the digital display and press ENTER (■).
9. The digital display will change to the current setting for BarGraph Full Scale:

10. **Apply the desired Full Scale input value into the BarGraph signal input terminals.** Use a calibrated lab-standard.
11. Press INCREASE (▲) or DECREASE (▼) to load the new Full Scale value into the meter.
12. Make sure the desired bar segment and digital display value are correct. Press and release the ENTER pushbutton. The desired Full Scale value is stored in memory and the displays change from the Full Scale value to the next setup function, **bAr**, if enabled.
13. Step the INCREASE (▲) pushbutton to scroll through the setup modes until you return to **rUn**.
14. Press ENTER (■). At this point, the BarGraph will return to normal operation.
15. Recheck your BarGraph's Zero and Full Scale values with the lab-standard input signal source and verify that you have accomplished the desired results.

3.2 NONLINEAR CALIBRATION

Nonlinear Calibration Commands

Due to the amount of information that must be provided for multi-point calibration, the TABLE function has four levels of sub functions. These levels are shown graphically below and each level is described in detail:

Level One

TABLE



Press ENTER to start multi-point calibration

Level Two



tblen



Pt 5

Press DECREASE to access table length

Press INCREASE to access table values

Level Three



Press ENTER to change the number of points in table.



Press INCREASE or DECREASE to enter a new number of points in the table.



The number of points may range from 3 to 49. Table points are numbered from 0 to (total pts - 1).



Press ENTER to save the new number of points



Press ENTER

Level Four

Pt 0

Display shows first point in table



Press INCREASE or DECREASE to increment or decrement the point number.



Press ENTER to access the calibration value at that point.



Press INCREASE or DECREASE and apply the input signal to calibrate the point. If no calibration is desired (only examine points) press ENTER.



Press ENTER to save calibration and advance to next point. Repeat for all points in the table.



WARNING: PREVENT DAMAGE TO YOUR BARGRAPH™!



The BarGraph™ was configured at the factory for certain Zero and Full Scale values. These values should not vary more than 20% or damage may occur during severe overrange conditions. Identify the Zero and Full Scale values from the INPUT data on the BarGraph™ label. If you need significant changes to your configuration, the input circuitry might require modification. Consult the factory for assistance.

Nonlinear Calibration Procedure

1. To calibrate the BG252TC or BH252TC, access to Supervisor Setup functions is required. To do this, the **PRSS** function must be accessed and the correct password entered as described on page 5 of this manual.
2. To enter the calibration table, press the INCREASE (▲) or DECREASE (▼) pushbuttons until the **tAbLE** appears on the digital display. Press ENTER (■).
3. There are two options under the **tAbLE** function: **tBLEn** and **PtS**. To set the number of points in the table (table length), **tBLEn** must be displayed and the ENTER (■) pushbutton pressed. Make sure that **tBLEn** appears on the digital display and press ENTER (■).
4. The display will change to show **3** (or previously set table length) on the digital display.
5. **Enter the number of points in the calibration table.** Press INCREASE (▲) or DECREASE (▼) to change the number of points in the table. The number of points in the table must be at least 3 and can be no more than 50.
6. When the correct number of points for the table are displayed, press ENTER (■). The new value for table length will be stored and the display will change to show **Pt0**, the first point in the table. At this point, the BarGraph instrument is ready to calibrate every point in the table.
7. Press ENTER (■). The display value for this point will be shown.
8. **Apply the desired input value for this point into the BarGraph signal input terminals.** Use a calibrated lab-standard.
9. Press INCREASE (▲) or DECREASE (▼) to enter the display value that corresponds to the input value set in step 8 above.

CAUTION: If this step is not performed, the new calibration point will not be saved. If the display value shown is correct you must still change it slightly (using the INCREASE or DECREASE keys) and then return to the proper value or the new calibration value for this point will not be saved.

10. Press ENTER (■) to save the new calibration value. The display will change to show the next point in the calibration table (for example, if **Pt0** was just calibrated, **Pt 1** will appear on the display).
11. Repeat steps 7 through 10 for every point in the calibration table. When the last point in the table is calibrated, pressing ENTER (■) will save the calibration for that point and exit the calibration function. The display will change to show the next setup function.

13. Step the INCREASE () pushbutton to scroll through the setup modes until you return to *run*.
14. Press ENTER (). At this point, the BarGraph will return to normal operation.
15. Recheck your BarGraph's calibration values with the lab-standard input signal source and verify that you have accomplished the desired results. Values between each of the calibration points should be checked to insure that accuracy is maintained across the full range of calibration values.

4 PHYSICAL DIMENSIONS

4.1 BG252TC and BH252TC Physical Dimensions

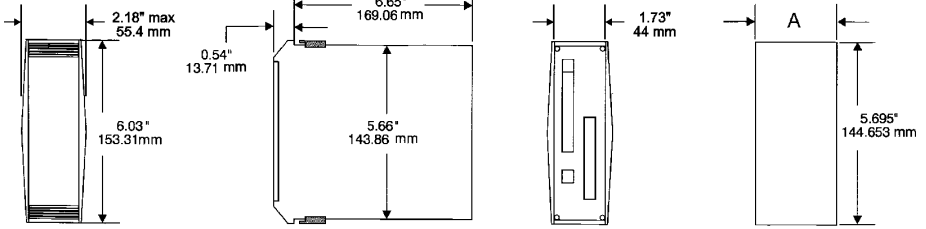

FRONT VIEW

SIDE VIEW

BACK VIEW

PANEL CUTOUT

Number of Instruments	A Inches (+0.00, -0.02)	A (millimeters) (+0.00, -0.51)
1	1.770	(45)
2	3.510	(89)
3	5.250	(139)
4	6.990	(178)
.	.	.
.	.	.
.	.	.
8	13.95	(354)

4.2 BG241TC Physical Dimensions

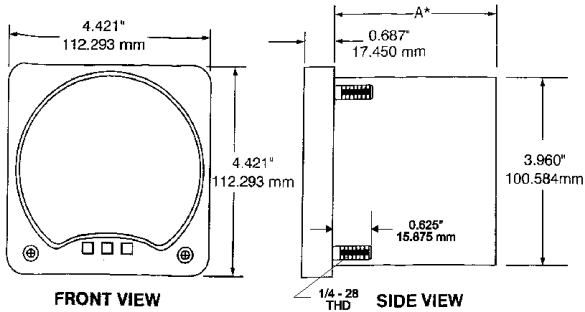

FRONT VIEW

SIDE VIEW

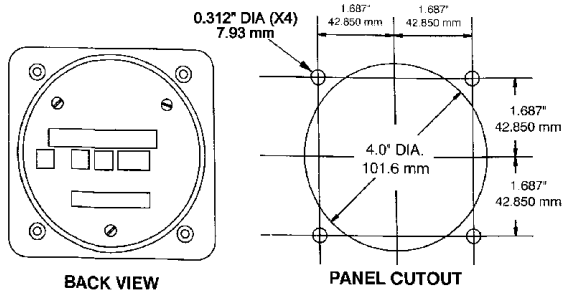

BACK VIEW

PANEL CUTOUT

4.3 BG261TC Physical Dimensions

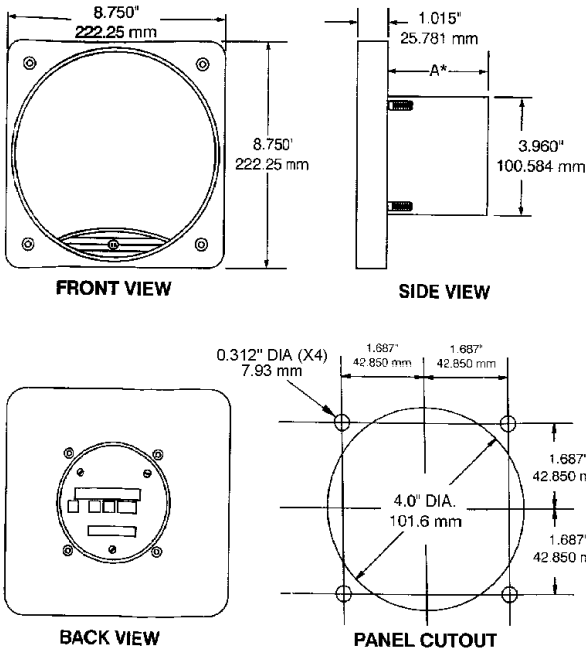

4.4 BG251TC and BG281TC Physical Dimensions

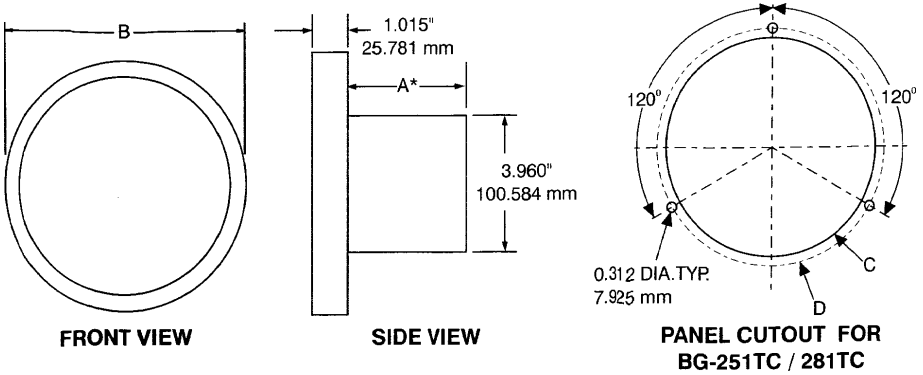

METER TYPE	Dim B Inches (mm)	Dim C Inches (mm)	Dim D Inches (mm)
BG-251TC	7.562 (185.27)	2.055-3.275 R (52.20-83.19)	3.440 R (87.38)
BG-281TC	10.062 (246.52)	2.055-4.455 R (52.20-113.16)	4.754 R (120.75)

4.5 Terminal Connections - BG-252TC and BH-252TC

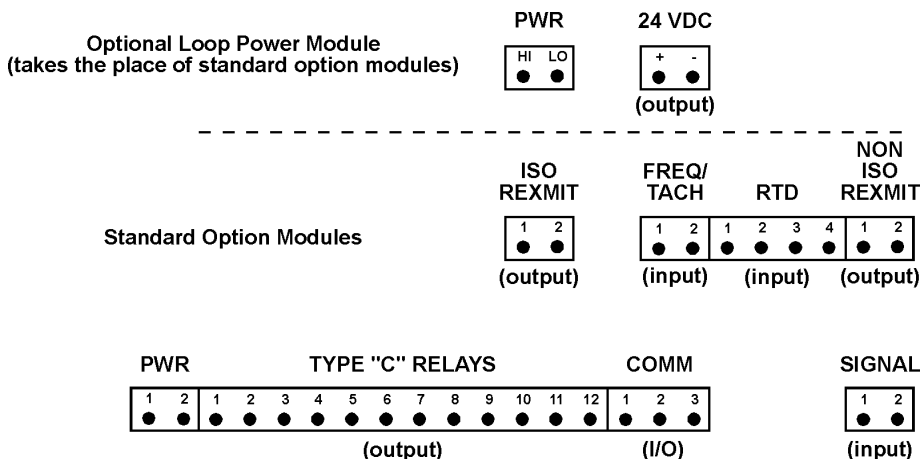

POWER

- (1) Hot Side (+)
- (2) Return Side (-)

RELAY CONTACTS*

- (1) Hi/Hi N.O.
- (2) Hi/Hi C.
- (3) Hi/Hi N.C.
- (4) Hi N.O.
- (5) Hi C.
- (6) Hi N.C.
- (7) Lo N.O.
- (8) Lo C.
- (9) Lo N.C.
- (10) Lo/Lo N.O.
- (11) Lo/Lo C.
- (12) Lo/Lo N.C.

- * N.O. = Normally Open
N.C. = Normally Closed
C. = Common

COMMUNICATIONS

- (1) Transmit
- (2) Common
- (3) Receive

SIGNAL

VOLTAGE/CURRENT

- (1) Return Side (-)
- (2) Hot Side (+)

RTD

- (1) Source (-)
- (2) Sense (-)
- (3) Sense (+)
- (4) Source (+)

FREQUENCY/ FREQUENCY TACHOMETER

- (1) Lead 1 (-)
- (2) Lead 2 (+)

THERMOCOUPLE

Provided w/ flying lead and plug.

AC LINE FREQUENCY

- (1) Hot Side (+)
- (2) Return Side (-)

AC Inputs have 6/32" barrier lug connections.

OUTPUTS

RETRANSMIT

- (1) Output (-)
- (2) Output (+)

4.6 Terminal Connections - BG-241TC, BG-251TC, BG-261TC and BG-281TC

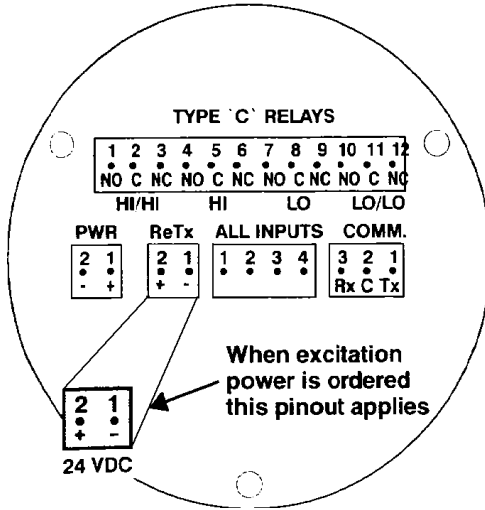

All Models except AC Amps and AC Volts

POWER

- (1) High Side (+)
- (2) Low Side (-)

COMMUNICATIONS

- (1) Receive
- (2) Common
- (3) Transmit

RELAY CONTACTS*

- (1) Hi/Hi N.O.
- (2) Hi/Hi C.
- (3) Hi/Hi N.C.
- (4) Hi N.O.
- (5) Hi C.
- (6) Hi N.C.
- (7) Lo N.O.
- (8) Lo C.
- (9) Lo N.C.
- (10) Lo/Lo N.O.
- (11) Lo/Lo C.
- (12) Lo/Lo N.C.

* N.O. = Normally Open
 N.C. = Normally Closed
 C. = Common

SIGNAL

DC VOLTAGE/CURRENT &
 AC MILLIAMPS

- (1) Positive (+)
- (2) Negative (-)

RTD

- (1) Source (-)
- (2) Sense (-)
- (3) Sense (+)
- (4) Source (+)

FREQUENCY TACHOMETER

- (1) Lead 1(-)
- (2) Lead 2 (+)

THERMOCOUPLE

Provided w/ flying lead and plug.

RETRANSMIT

- (1) Output (+)
- (2) Output (-)

LOOP POWER

- (1) Output (-)
- (2) Output (+)

4.6 Terminal Connections - BG-241TC, BG-251TC, BG-261TC and BG-281TC

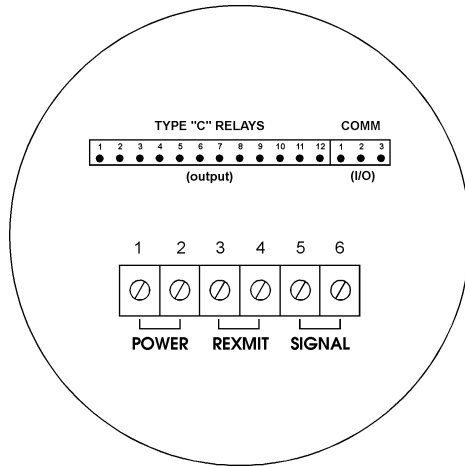

AC Amps and AC Volts Only

COMMUNICATIONS

- (1) Receive
- (2) Common
- (3) Transmit

RELAY CONTACTS*

- (1) Hi/Hi N.O.
- (2) Hi/Hi C.
- (3) Hi/Hi N.C.
- (4) Hi N.O.
- (5) Hi C.
- (6) Hi N.C.
- (7) Lo N.O.
- (8) Lo C.
- (9) Lo N.C.
- (10) Lo/Lo N.O.
- (11) Lo/Lo C.
- (12) Lo/Lo N.C.

* N.O. = Normally Open
N.C. = Normally Closed
C. = Common

POWER

- (1) Low Side
- (2) High Side

RETRANSMIT

- (3) Output (-)
- (4) Output (+)

SIGNAL

- (5) Input Low
- (6) Input High

5 Configuration Flowcharts

Operator Setup

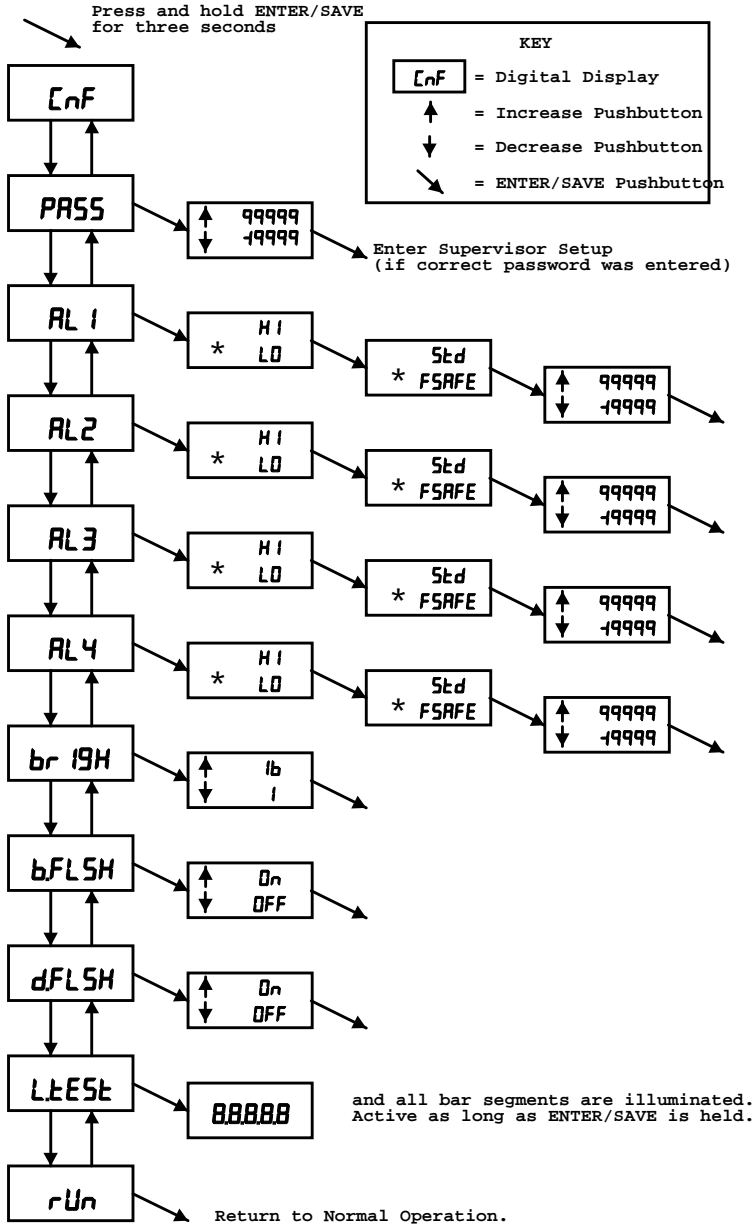

*These settings may be examined but cannot be changed in Operator Setup.

Supervisor Setup

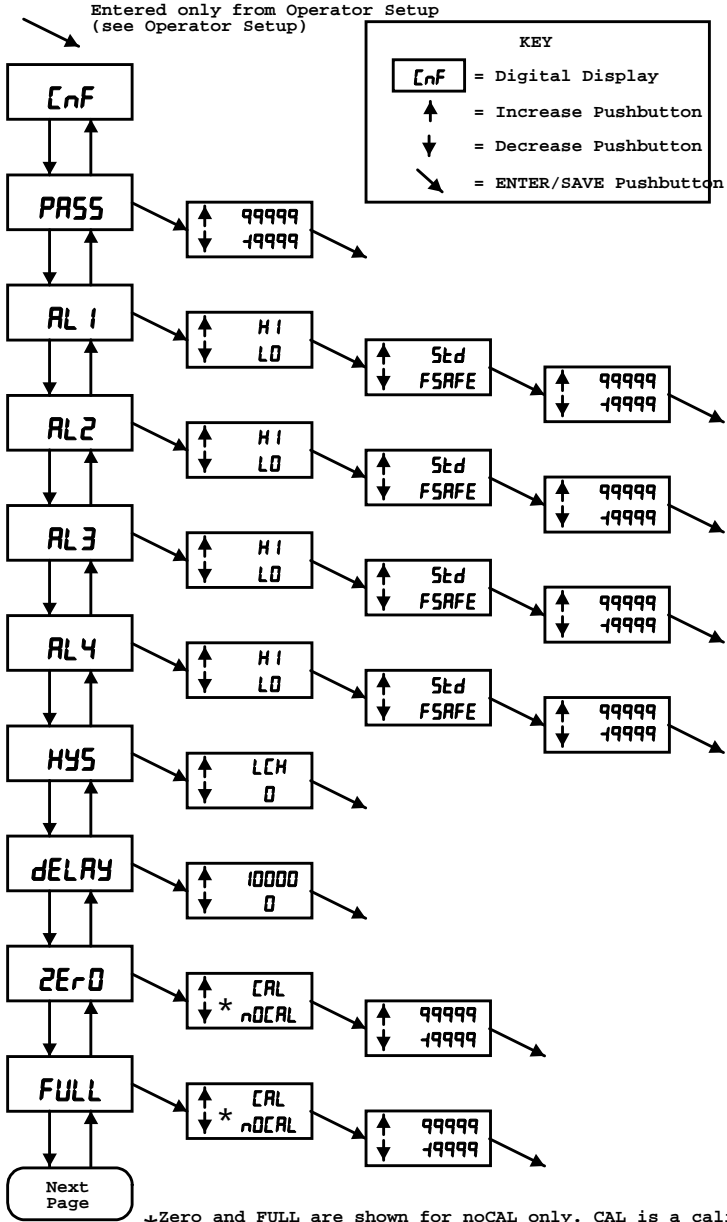

*Zero and FULL are shown for noCAL only. CAL is a calibration and requires a laboratory standard. Please see Section 3, Cal

Supervisor Setup

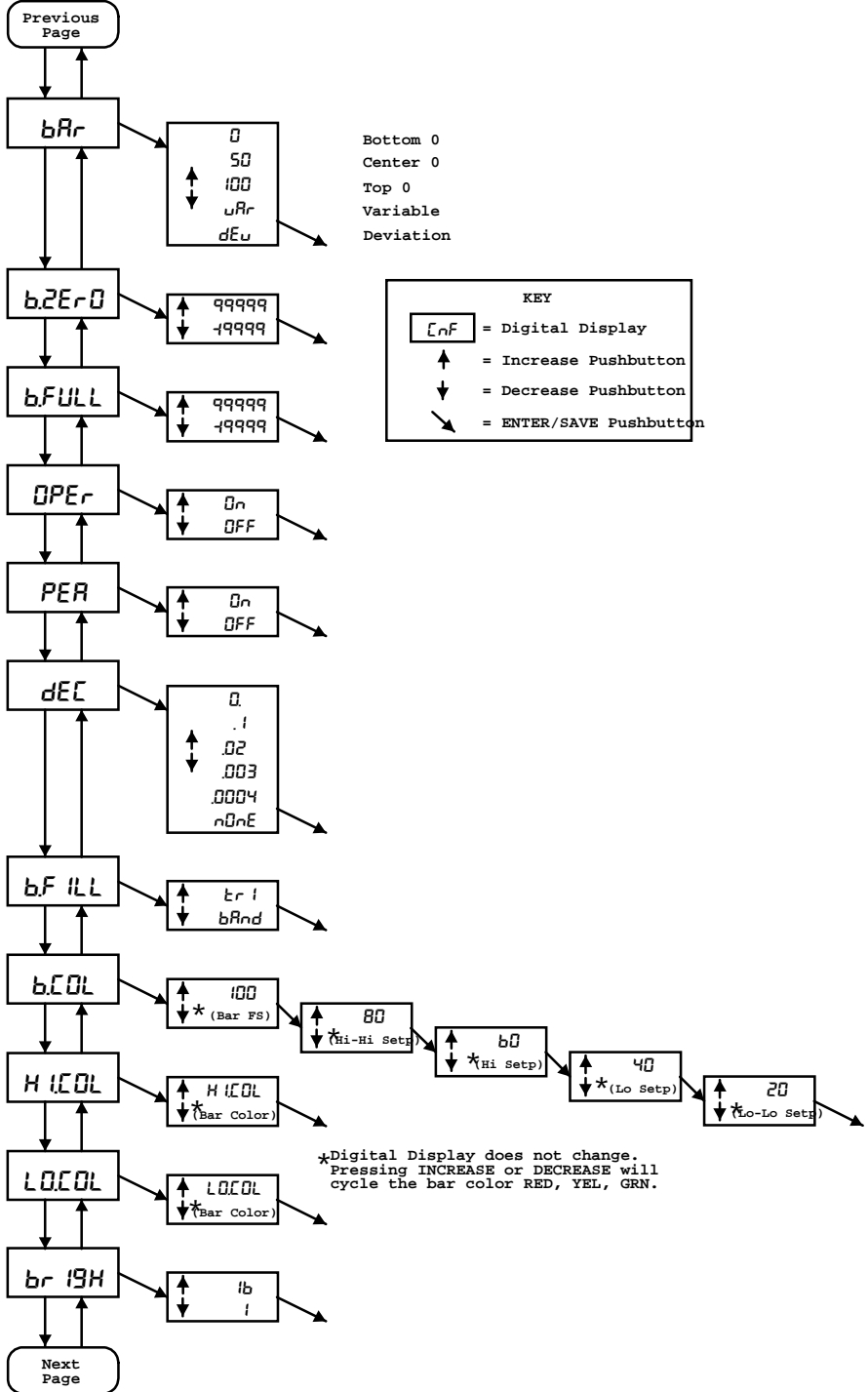

Supervisor Setup

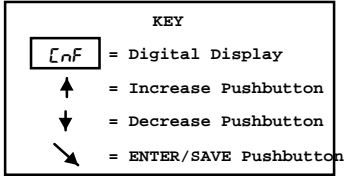
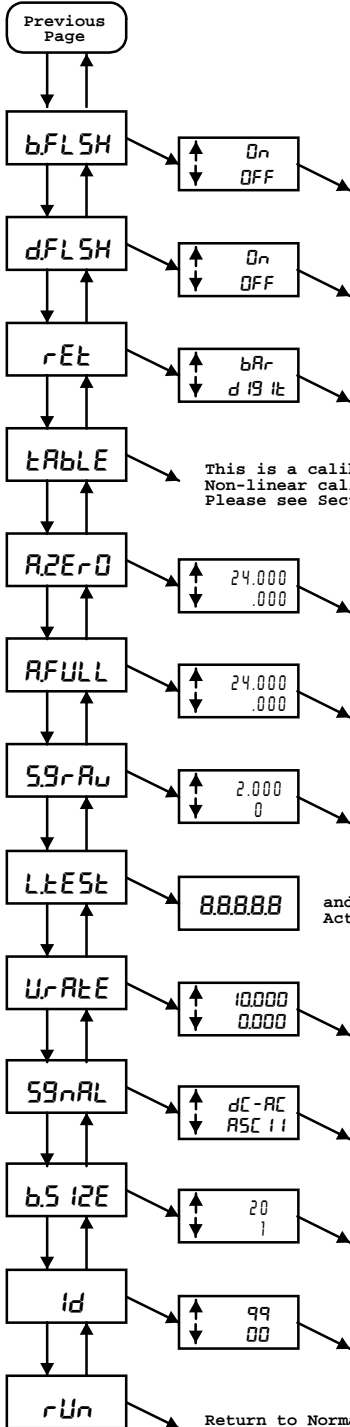

This is a calibration function and requires a laboratory stand:
 Non-linear calibration will be enabled at the factory if required.
 Please see Section 3, Calibration, for a detailed Calibration P:

and all bar segments are illuminated.
 Active as long as ENTER/SAVE is held.

6 WARRANTY

All BarGraph products from Weschler Instruments are warranted against defects in material and workmanship for a period of two years from date of delivery. Weschler Instrument, at its option, will repair or replace all defective instruments returned to it during the warranty period without charge, provided there is no evidence that the equipment was mishandled or abused. Any repairs or modifications not performed by an authorized factory representative are not warranted by Weschler Instruments. Field service is only available on a contract basis.

Customers must contact Weschler Instruments for an RMA number and shipping instructions BEFORE returning any instrument.

All products returned to Weschler Instruments must be insured by sender and carefully packaged to prevent breakage from shock and rough handling. All applicable shipping charges, insurance, duties and taxes must be paid by sender.

WARNING !

Removal of the instrument case may expose hazardous voltages. Service on Weschler BarGraph products must be performed only by a qualified service technician.

These instruments have an internal, board mounted protection fuse on the power supply lines. Fuse rating depends on the power supply option installed. Replace fuse only with one having an identical size & rating.

7 SPECIFICATIONS

Bar Display

Edgewise: 40 segment LED, 2.5% resolution
4" height

Circular: 50 segment LED, 2% resolution
285° span (BG-241)
270° span (BG-261/281)
345° span (BG-251)

Digital Display

Resolution: 5 digits, 0.01%
Linearity: ± 1 count
Height: 0.3" (7.62mm) - Edgewise
0.4" (10.62mm) - BG-241
0.8" (20.32mm) - BG-261/281
0.56" (14.22mm) - BG-251

Response Time

DC: < 600 msec full scale
AC: < 800 msec full scale

Temperature

Operating: 0 to 50°C
< 95% RH non-condensing
Storage: -40 to 85°C

Sensor Power

24 VDC excitation power @ 90 mA

Setpoints

Up to 4 SPDT (form C) reley contacts
Hysteresis: 0 to 10% FS or latching
Time Delay: 0 to 10 seconds

Retransmit Signal

0 to 1 mA, 4 to 20 mA, 10 to 50mA
0 to 5 VDC, 1 to 5 VDC

Communications

RS-232, RS-485 optional

Power

120/240 VAC $\pm 15\%$, 50/60/400 Hz, 13 VA
12, 24, 28, 48, 125 or 250 VDC $\pm 10\%$, 8W

Input Sensitivities (ANSI C39.1)

Frequency (50 Hz to 20 kHz)
Level 5 to 250 V p-p
Accuracy 0.1 % of full scale ± 1 count

Line Frequency (55 Hz to 65 Hz)
Accuracy 0.01 % of full scale ± 1 count

DC:

Current 50 μ A to 5A
Voltage 50mV to 250V
Accuracy 0.04 % of full scale ± 1 count

RMS:

Current 50 mA to 5A AC
Voltage 1 to 250V AC
Accuracy 0.1 % of full scale ± 1 count

Thermocouple:

	°C	°F
Type J	-210 to 795	-346 to 1463
Type K	-270 to 851	-454 to 1563
Type T	-270 to 400	-454 to 752

Accuracy 0.1 % of full scale ± 1 count
Linearity 50 point, 0.1 %

RTD:

	°C	°F
100 Ω Pt	-260 to 400	-436 to 752
$\alpha = 0.00385$ standard, others available		
10 Ω Cu	-100 to 260	-148 to 500

Accuracy 0.2 % of full scale ± 1 count

Input Overload

200%, not to exceed 10A or 250V

Input Isolation

AC: Transformer Isolated
(> 50mA, 1V)

DC: Differential

Input Impedance

2 M Ω @ > 4VDC
30 k Ω @ 120 VAC P.T.
0.1 Ω @ 5A AC C.T.
250 Ω @ 4-20 mA DC
100 Ω @ 10-50 mA DC